

E100 SA Autowrap

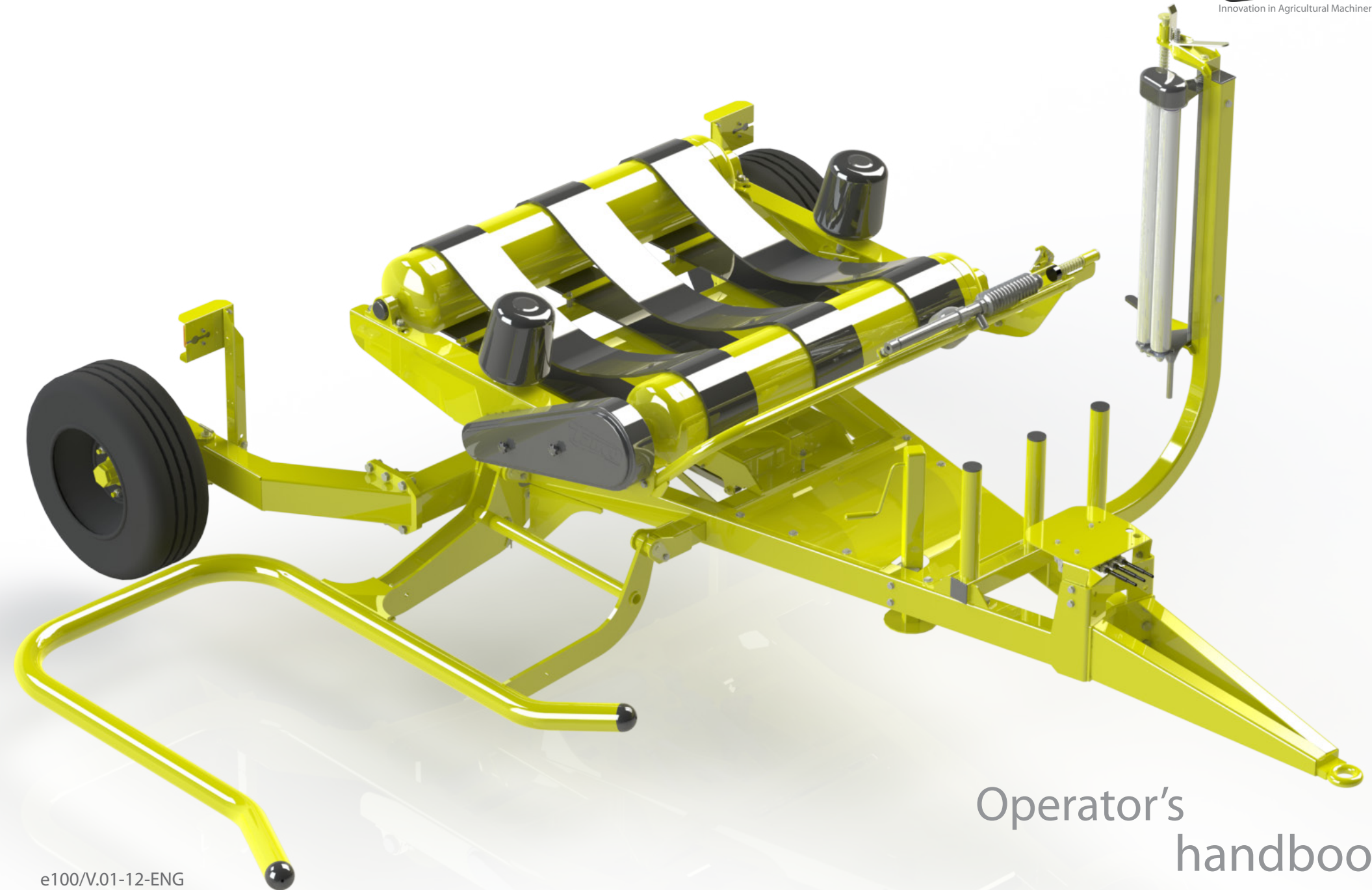

Operator's
handbook

TABLE OF CONTENTS

Chapter	Contents	Page
1	SAFETY DECALS	2
2	INTRODUCTION	3
3	TECHNICAL SPECIFICATIONS	5
4	SAFETY PRECAUTIONS	7
5	BALE WRAPPING	12
6	MACHINE SETUP	14
7	CONTROLLER INFORMATION	25
8	ELECTRO-HYDRAULICS	32
9	TROUBLESHOOTING	37
10	MAINTENANCE	40
11	GUARANTEE	42
12	DECLARATION OF CONFORMITY	43

The following safety decals have been placed on your machine in the areas indicated. They are intended for your personal safety and for the safety of the other people working with you. Walk around your machine and note the content and locations of these warning signs. Review these decals and the operating instructions in the manual with your machine operators. Ensure that these decals are always legible. If they are not, replace them.



1. Read the operator's manual carefully



2. Stand clear of the machine when in operation

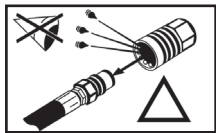

3. Hoses are under pressure at all times



4. Do not exceed Turntable speed of 30 R.P.M



5. Read the operator's manual for correct operation



6. Ensure that nuts are kept tight at all times

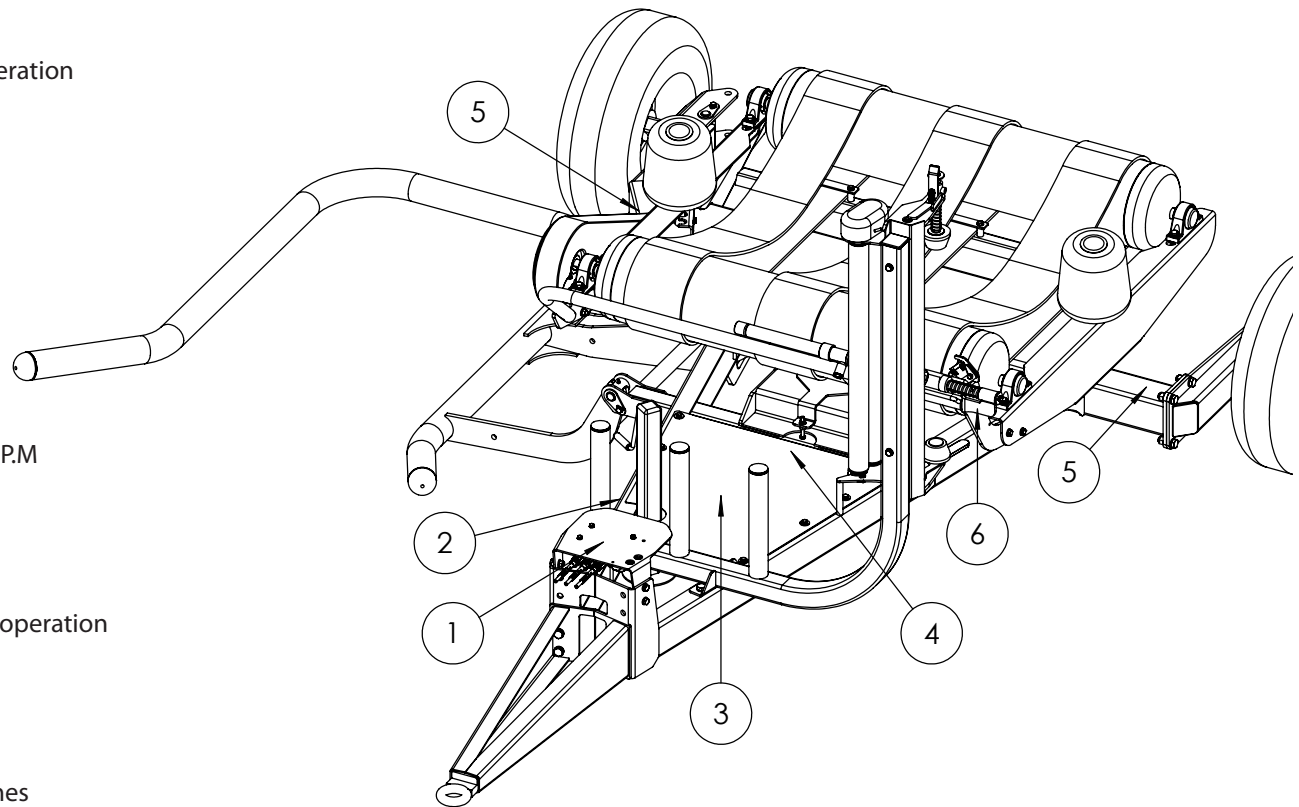

Tanco Autowrap Ltd congratulates you on your choice of the TANCO AUTOWRAP E100 SA bale wrapping machine. We are certain you will be satisfied with the machine, and that you will have the pleasure of your investment for many years.

This manual is meant to explain how TANCO AUTOWRAP E100 is setup, attached to tractor, used and how it works, and shall together with the spare part's list be a reference for maintenance and troubleshooting. So take good care of this book; it is a part of the machine.

Read carefully through this manual, and especially the safety instructions, before starting the machine. Follow the instructions thoroughly, if problems should occur, check the troubleshooting guide to try to establish the problem. Ask your dealer for advice before you attempt anything that may make the problem worse.

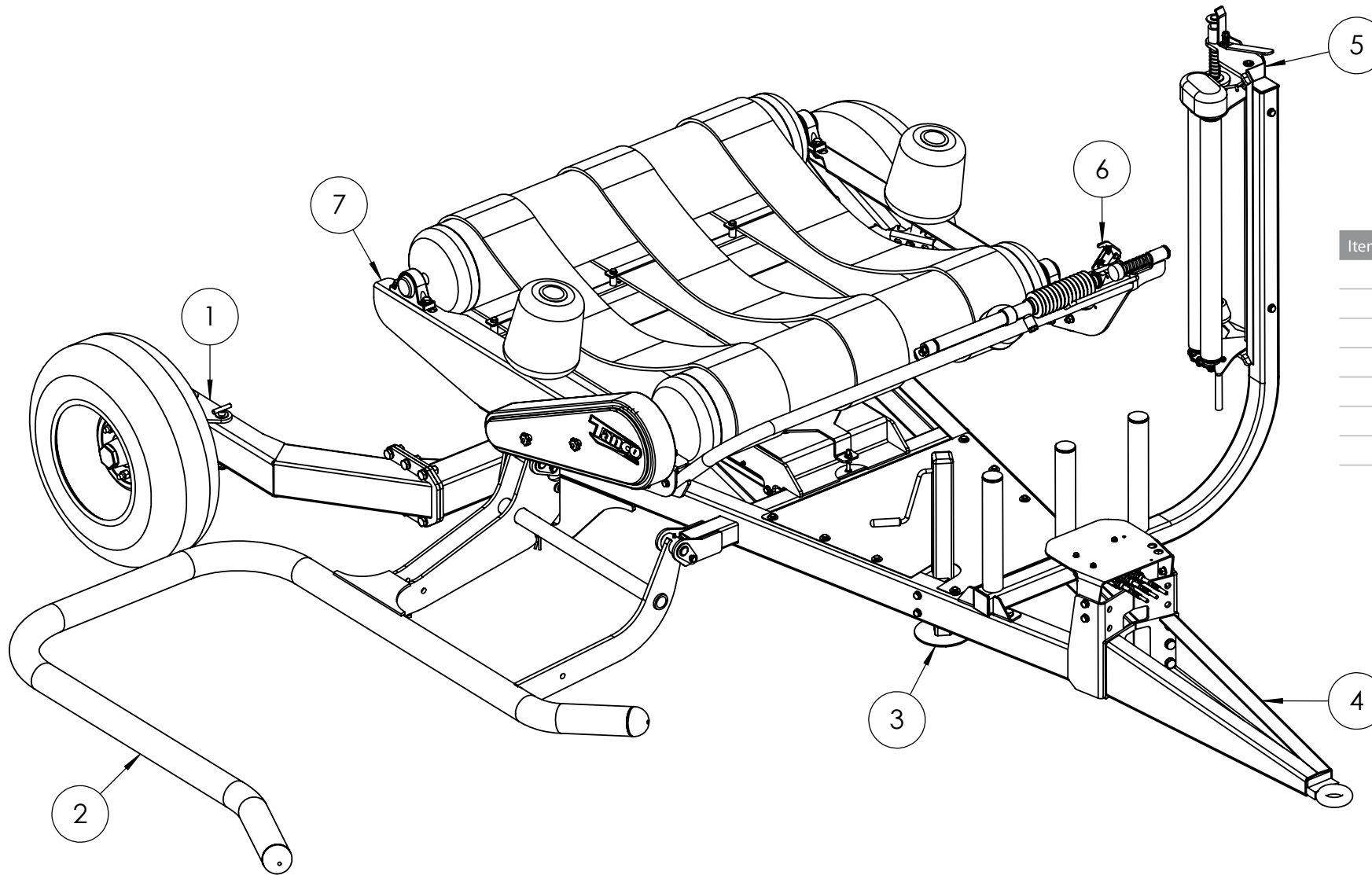

Item No.	Description
1	Swivel Axle
2	Load Arm
3	Jack
4	Hitch
5	Dispenser
6	Cut & Tie Assembly
7	Turntable

Technical Specifications	E100 SA Autowrap
Height	2370mm
Width (Working)	2476mm (3805)
Length	4360mm
Weight	960Kgs
Wrapping Table Speed (Recommended)	28 R.P.M
Wrapping Table Speed (max)	30 R.P.M.
Maximum Bale Diameter	1500mm
Maximum Bale Weight	1000 kg
Pre-Stretcher(s)	1 x 750mm Width; 55 & 70% Stretch
Hydraulic Connection	
Oil Pressure	150 bar
Oil Amount	25 lts/min
Maximum Counter Pressure	10 bar
Electrical Connection	12 V DC

Optional Equipment
Road Light Set
500mm Film Adaptor
Bale End Tip
Standard Hitch Drawbar
High Hitch Drawbar
Clevis Hitch Drawbar

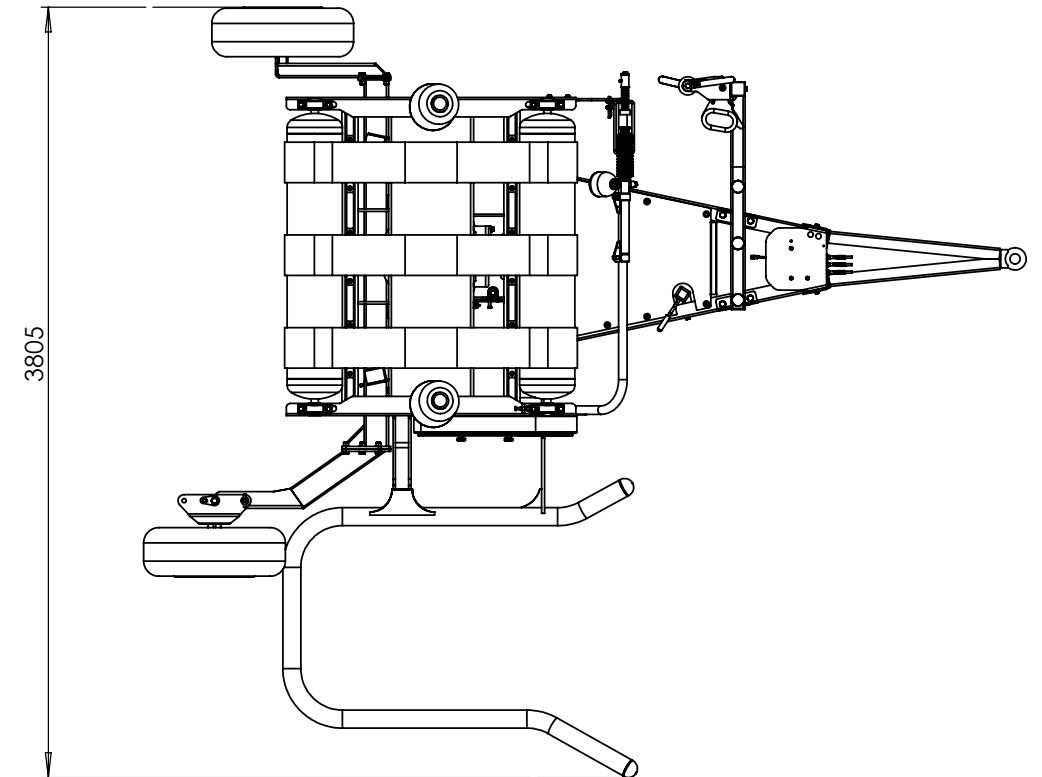
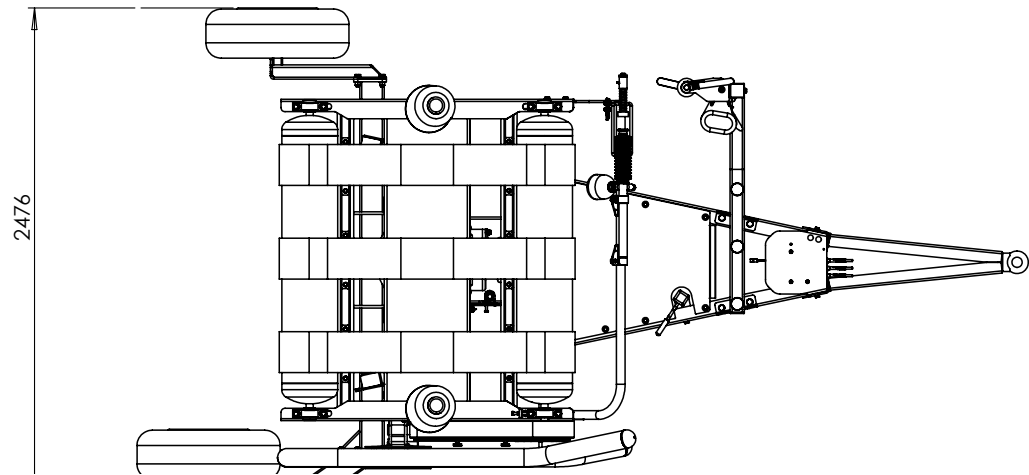
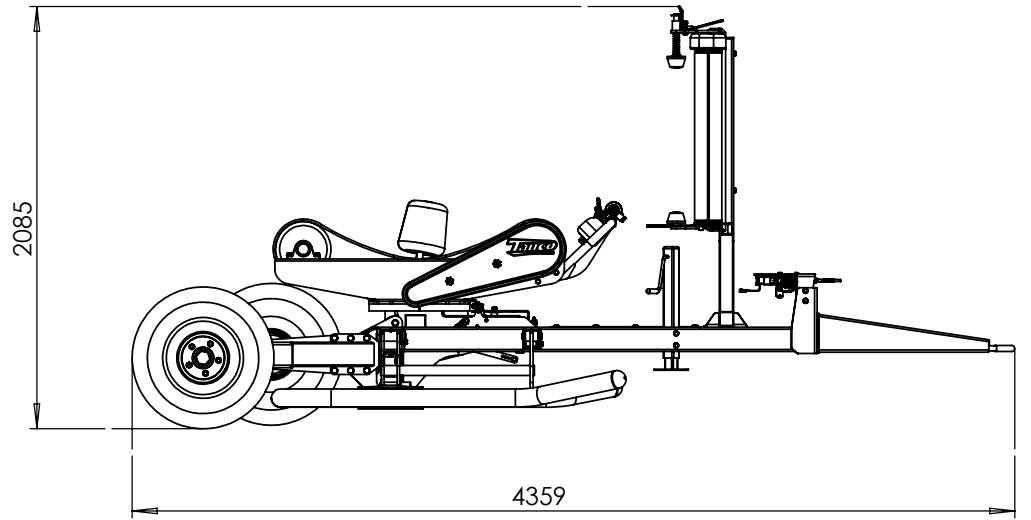
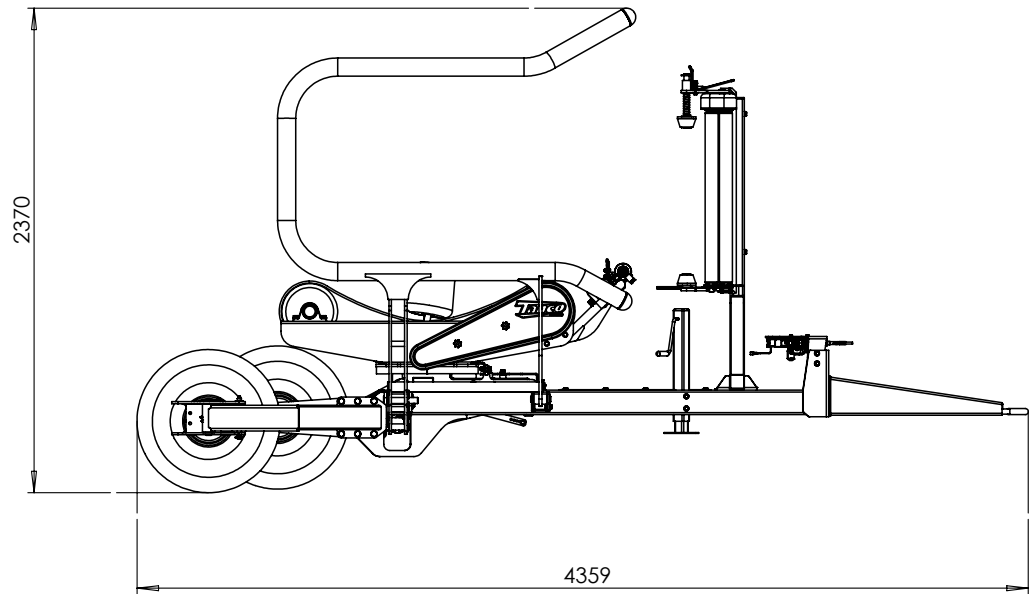

GENERAL SAFETY RECOMMENDATIONS

Basic Principles

Before operating the machine, always ensure that the tractor and machine meet with work safety and road traffic regulations.

1. In addition to recommendations given in this manual, legislation on work safety and accident prevention must also be respected.
2. Advice is indicated on the machine, specifying safety recommendations in order to prevent accidents.
3. Before travelling on public roads, the operator must ensure that the machine conforms to road traffic regulations.
4. Before starting work, the operator must be familiar with all the machine controls, handing devices and their functions. Once at work, it is too late to do this!
5. Do not wear loose clothing, which could become caught up in moving elements.
6. The tractor should be equipped with a safety cab.
7. Before starting up the machine and begin work, check the surrounding area (beware of children!). Make sure there is sufficient visibility.
keep all people and animals away from the danger zone of the machine (risk of protection!!).
8. Carrying people or animals on the machine when working or transport is strictly forbidden.
9. Machine must only be attached to tractor using means provided and in accordance with current Safety standards.
10. Special care should be taken when attaching or removing the machine from the tractor.
11. Before transporting the machine on public roads, ensure that all legally required guards and indicators (lights, reflectors...) are in place and in good operations.
12. All operating controls (cords, cables, rods etc.) must be positioned so that they cannot be set off accidentally, risking accident or damage.
13. Before travelling on public roads, put the machine into it transport position as instructed in this operator's manual.
14. Never leave the tractor seat while the machine is operating.
15. Drive speed must be adapted to ground conditions as well as to roads and path. Always avoid abrupt changes of directions.



16. Before operating the machine, ensure that all safety guards are firmly in place and in good condition. If worn or damaged, replace immediately.
17. Before operating the machine, check the tightness of all nuts and bolts, particularly on fixing elements (blades tines, knives, spades etc.).
18. Keep clear of the machine operating area.
19. Warning! Danger of crushing and shearing can exist when components are operated by hydraulic or pneumatic controls.
20. Before leaving the tractor or before adjusting, maintaining or repairing the machine, turn off the engine, remove the ignition key and wait until all moving parts have come to a complete stop.
21. Do not stand between the tractor and the machine unless the hand break is tight and/or stops have been placed under the wheels.
22. Before any adjustments, maintenance or repairs are carried out, ensure that the machine cannot be started up accidentally.

Attaching Implements to Tractor

1. When attaching or removing the machine from the tractor, position hydraulic lift control lever in such a way that it cannot be set off accidentally.
2. When attaching the machine to the tractor hydraulic linkage, ensure that diameter of the link pins corresponds to the diameter of the ball joints.
3. Warning! Danger of crushing and shearing can exist in the lifting zone of the tractor hydraulic linkage!
4. Do not stand between the tractor and the machine when operating the outer lever of the lift mechanism.
5. In transport, the machine lift mechanism should be stabilized by the tractor tie rods, to avoid flotation and side shifting.
6. When transporting the machine, lock the hydraulic lift control lever in place so that it cannot be lowered accidentally.

Hydraulic Systems

1. Warning! Hydraulic system is under pressure.
2. When fitting hydraulic motors or cylinders, ensure that connections have been made correctly, as per manufactures instructions.
3. Before connecting hoses to the tractor hydraulics, ensure that tractor and machine circuits are not under pressure.



4. It is strongly recommended that the operator marks the hydraulic connections between tractor and machine to avoid making a wrong connection.
Warning! Functions could be reversed (For example: lift/lower)
5. Check hydraulic hoses regularly! Worn or damaged hoses must be replaced immediately. Replacement parts must be in accordance with the manufactures recommendations concerning specifications and quality.
6. Should a leak be found, take all necessary precautions to avoid accidents.
7. Any liquid under pressure (particularly oil from hydraulics) can be penetrate the skin and cause severe injury. If injured, see a doctor immediately, there could be a danger of infection.
8. Before any adjustments, maintenance or repairs are carried out, lower the machine, depressurize the circuit, turn off the engine and remove the ignition key.

Safe Maintenance

1. Before checking for any machine malfunction and before adjusting, maintaining or repairing the machine turn off engine and remove ignition key.
2. Check tightness of nuts and bolts regularly. Retighten if necessary.
3. If the machine is raised, prop it up in a stable position before carrying out any maintenance work
4. When replacing a work part, wear protective gloves and use only standardized tools.
5. It is forbidden to discard any oil, grease or filters. These must be given to waste disposal organizations to protect the environment.
6. Disconnect power source before any work is done to the electric system.
7. Check safety guards regularly, particularly those that are subject to wear. Replace immediately if damaged.
8. Spare parts used must be in accordance with specifications and standards as defined by the manufacturer. Use only genuine TANCO parts.
9. Before any electric welding is carried out on tractor or attached machine, disconnect generator and battery terminals.
10. Repairs on elements under pressure or tension (spring, accumulators etc.), must only be carried out by competent persons with standardised equipment.

Special Safety Instructions

1. Stop engine of the tractor before working on machine.
2. Use the Safety Bar (1) to prop up the Tip Frame (2) before attempting to carry out work in this area. (See Fig 1.1)
3. During machine operation the Safety Pin (1) is fitted to the Load Arm (2) as shown in Fig 1.2
3. During transport the Safety Pin (2) must be fitted the opposite way as shown in Fig 1.3
4. Always raise lift Arm and fit Safety pin before transporting machine on public roads.
5. Lift Arms should always be lowered before operating turntable.
6. Ensure platform rollers are parallel to Lift Arm before arm is raised.

Fig 4.1 Propping Tip Frame

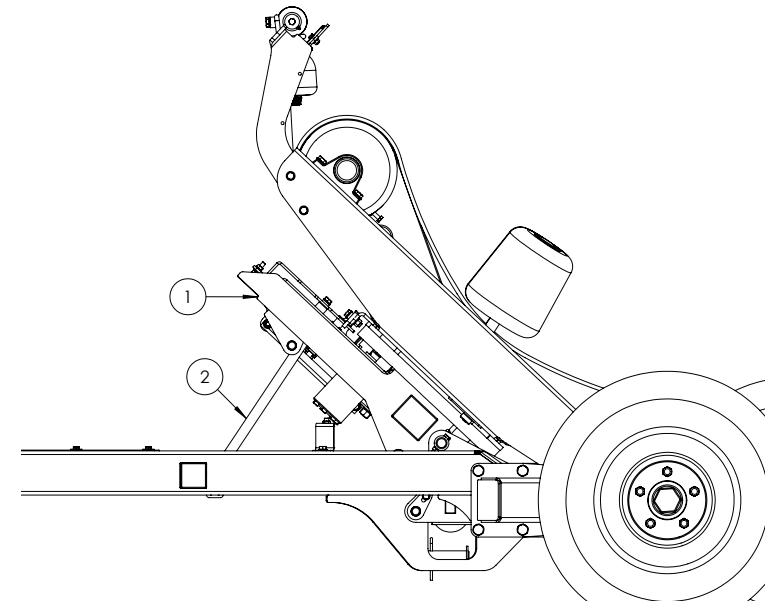

Fig 4.2 Loading Arm Safety Pin; Work Position

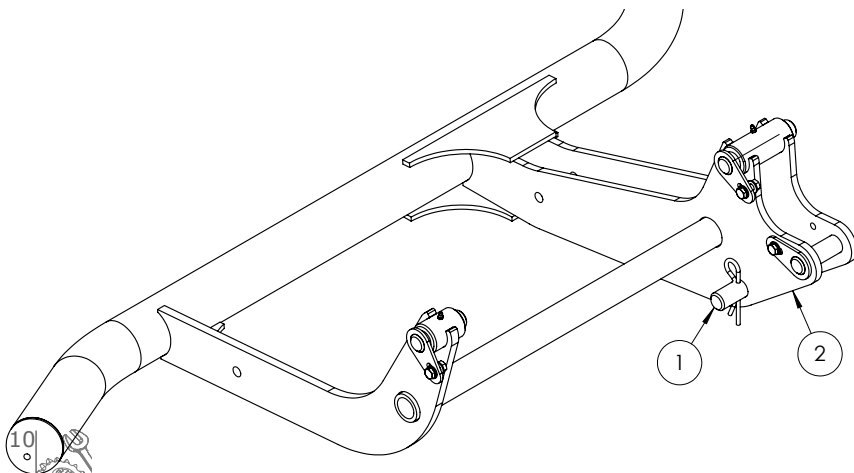
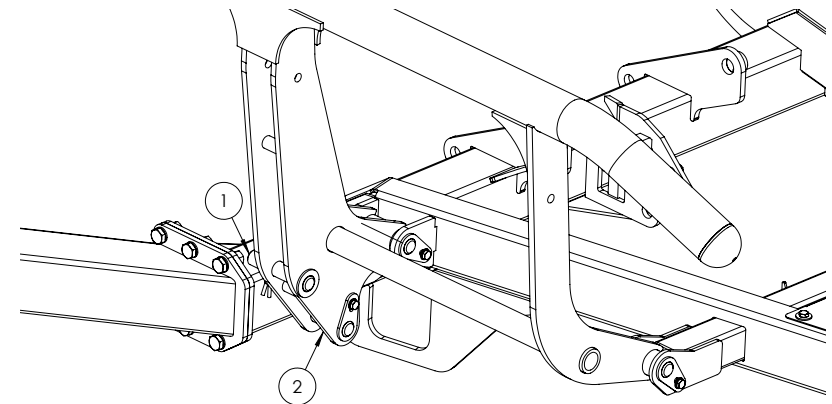

Fig 4.3 Loading Arm Safety Pin; Transport Position



Operating Safety Instructions

1. Operators should have their hands on the controls at all times when the machine is in use.
2. Autowrap control unit and level controls must remain in the tractor cap at all times. The operator must at no time leave the tractor cab when the machine is in motion.
3. Keep onlookers clear of machine at all times. Danger zone is 5 meters.
4. Beware of rotating turntable and all moving parts.
5. If not operated correctly the bale could fly off the turntable. The end support rollers must always be fitted. Do not exceed recommended turntable speed of 30 rpm. Misshapen bales combined with excessive turntable can be dangerous.
6. Care must be taken when tipping bales from the machine on sloping ground and during subsequent handling to ensure that they do not roll, thus causing hazard.

THINK OF YOUR PERSONAL SAFETY AND THAT OF OTHERS AT ALL TIMES

Bale Wrapping Principles

The advantages of round bale silage are many, and include fewer feed units, a flexible harvesting system, large capacity and the possibility of selling feed units.

In principle, the same fermentation processes occur whether the fodder is placed in a silo or pressed into bales and packed in plastic, i.e. lactic acid fermentation in anaerobic conditions. The oxygen in the bale must be exhausted before fermentation begins.

The grass should be dried to approximately 30-40% solid content. The solid content can be determined by twisting the grass by hand. If drops of liquid are forced out of the grass, the solid content is less than 25%. Low solid content (wet grass) can lead to increased butyric acid fermentation if preservatives are not added to the grass. If the solid content is too high, (over 50%), normal fermentation will not take place and there will be enough oxygen in the bale to produce mould fungus.

The Baler

It is vital that the baler produces compact, well-formed bales, as misshapen bales can be difficult to wrap. Wrapping will also often take longer, thereby increasing the amount of plastic used.

Difficult Bales

When a misshapen bale is wrapped, it will have a tendency to move outwards or inwards on the roller. If the bale begins to move outwards, the machine must be lifted slightly at the rear edge to get the bale to rest against the support roller on the main frame. It can therefore be useful to use a hydraulic top link to make this adjustment easier.

If the bale to be wrapped is conical you must ensure that the sharp end is pointed at the tractor. It will then be easier to get the bale to lie correctly during packing. It is easy for such a bale to "turn" forward in the direction in which it is pointing, and therefore lie against the support rollers. If the bale is lying on a slope it must be picked up from the lower side. A hydraulic top link will again be advantageous.

Types of Plastic

A good type of plastic with good adhesive properties, and which is recommended for bale wrapping, must be used. The thickness of the plastic foil should be at least 25 μ . (25/1,000 mm). In order that the plastic tightens sufficiently around the bale, it is stretched before being wrapped, so it is somewhat thinner when it is put on the bale. With short-term storage (up to eight weeks) it is recommended that bales have a minimum of four layers of plastic at the thinnest points, with at least 52-53% overlap.

For long-term storage, or when the grass is wet when it is wrapped, the bale should have 90-100 μ plastic (six layers) and the same amount of overlap. If thinner plastic is used, more layers should be applied. If it is very hot the plastic will be stretched further, and more layers should be applied. It is better to have slightly too much than too little plastic on the bale.

From experience, light colored plastic produces slightly lower temperatures within the bale, and tends to improve feed quality.

Storage Location

Care should be taken in finding a suitable location for the storage of bales. The storage location should preferably be prepared before the bales are laid out. An elevation close to well-drained roads is recommended. If the wrapped bales are simply placed on stubble there is a danger of the plastic being pierced. A tarpaulin or a thin layer of sand should therefore be laid where the bales are to be stored over the winter.

Bales should be stored in the shade as far as possible. This reduces the danger of air leakage in the bales. A bale which is stored in sunlight and which therefore undergoes greater swings in temperature "pumps in" a great deal of air in comparison to a bale stored in the shade. According to "Teknik for Lantbruken" [Technology for Agriculture] in Sweden, a bale stored in the shade has only 40% of the air leakage of a bale which is stored in sunlight.

Stacking / Protection

If bales are hard and well formed, they can be stacked vertically, but loose and misshapen bales with low solid content should not be stacked higher than one layer, as this could easily cause deformity and the danger of runoff will be increased.

Bales can also be stored on their sides. The layer of plastic is thicker here, providing greater protection against piercing.

Bales should be covered with a tarpaulin or a fine-mesh net to protect against birds and small rodents. If the plastic is pierced, it must be sealed with weatherproof, hard-wearing tape, preferably under the outermost layer of plastic. Ensure that the hole is adequately sealed.

For Best Wrapping Results...

1. Harvest the grass early.
2. Ensure the grass is dried out to 30-40% solid content. If there is a danger of rain, bale and wrap the grass anyway.
3. Take care not to mix any earth in with the grass.
4. Use a baler that produces even, firm bales. Bales 1.2mtrs in width and with a diameter of 1.2-1.5mtrs are preferred sizes.
5. Wrap the bales as soon after baling as possible; never more than two hours afterwards.
6. Use a good plastic type, applying six layers of plastic. This removes the need to use preservatives.
7. Store bales in the shade to reduce the danger of air leakage.

Hitching the Machine (See Fig. 6.1)

Before attempting to hitch the wrapper to the tractor remove the lower links of the tractor to avoid them touching the drawbar (1). The machine can be hitched to the tractor using the towing hook of the tractor. Prior to hitching to the tractor the correct height of the hitch eye (2) must be determined. Please note that the drawbar can be turned upside down (See Fig 6.2) to accommodate a high or low attachment level, height adjustment can also be achieved by choosing one of three heights when connecting drawbar to the Chassis front adjustment plate (3). There are three types of drawbars available with this machine providing three hitching options depending on the tractor towing mechanism; Standard Hitch (shown), Clevis Hitch & High Hitch. Once an appropriate hitch height has been determined the Chassis height can be raised and lowered by turning the handle on the jack (1) clockwise and anti-clockwise respectively. Once the machine has been hitched to the machine fully re-tract the jack by turning the handle clockwise.

 Never stand between the tractor and the machine during hitching and ensure both the tractor and machine are prevented from rolling away.

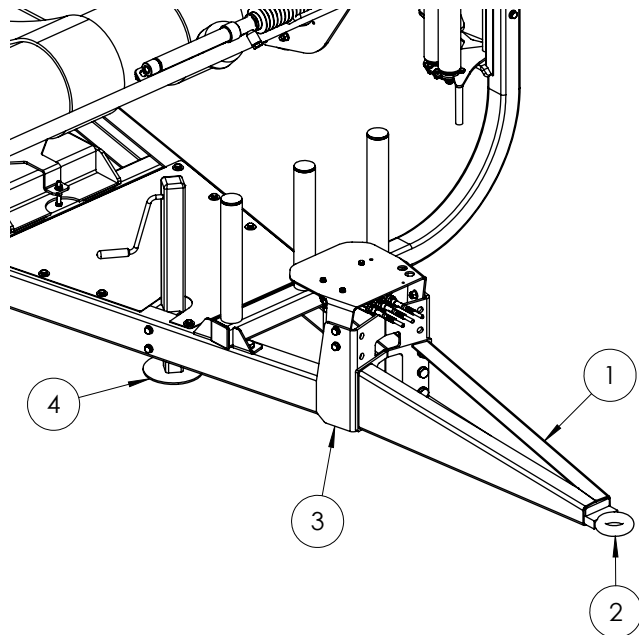

Fig. 6.1

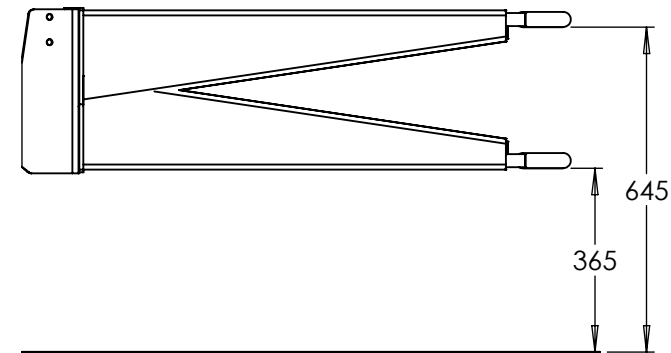

Fig. 6.2

Electrical Control Unit

The E100 Control Unit should be mounted in the tractor cab. Mount it in a position where it is dry, in reached and easily visible to the operator. Connect the unit directly to a 12V electrical supply using the 3 pin 'Cobo' plug. A good reliable power supply is important so do not connect indirectly to the tractors electrics. Polarity is important for the power supply, if using a connector other than the one supplied connect:

Brown to +
Blue to -.

Connect the 12 pin controller communication cable to the cable coming from the machine.
The control unit is powered on with the switch located on the back.
When the machine is not in use the Control unit should be stored in a safe dry place.

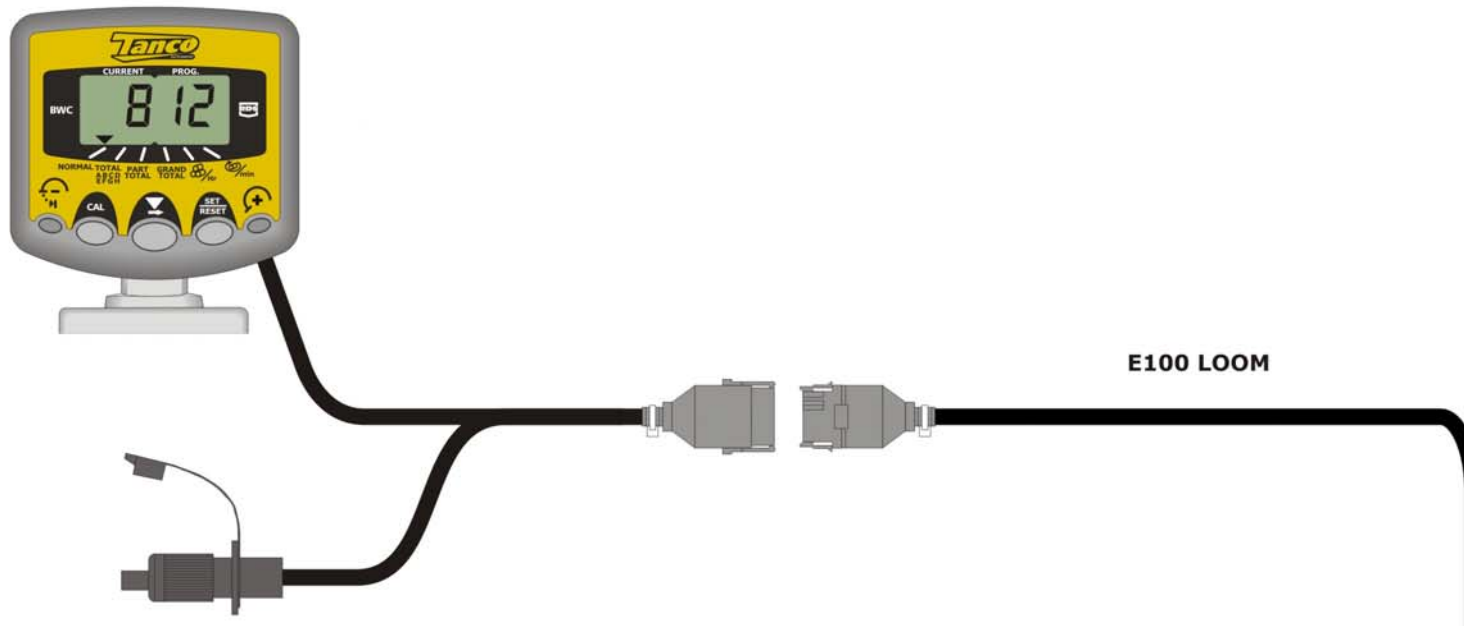

Hydraulic Connection

Connect the hydraulic feed hose (with the red dust cap) to a single or double acting remote coupling on the tractor. Make sure the coupling is not under pressure when connecting. The return hose should be connected to a free return coupling on the tractor.

NOTE: The return hose is fitted with a non-return valve to protect the Autowrap from damage in the event of incorrect connecting to the tractor hydraulics.

NOTE: To ensure the maximum efficiency and longevity of hydraulics components this machine requires a clean supply of hydraulic oil.

IT IS RECOMMENDED THAT THE TRACTOR HYDRAULIC FILTER ELEMENT TO BE REPLACED AND THERE AFTER MAINTAINED IN ACCORDANCE WITH THE MANUFACTURES RECOMMENDATIONS.

Control Levers

Mount the control levers (1) in the tractor cab on the mounting (2) and socket (3) supplied see fig 6.3. Place them in a position that is in comfortable reach of the driver and where he has good visibility of the machine when operating them. Route the control cables to avoid sharp edges and bends. Allow for movement of the cables when the tractor is turning.

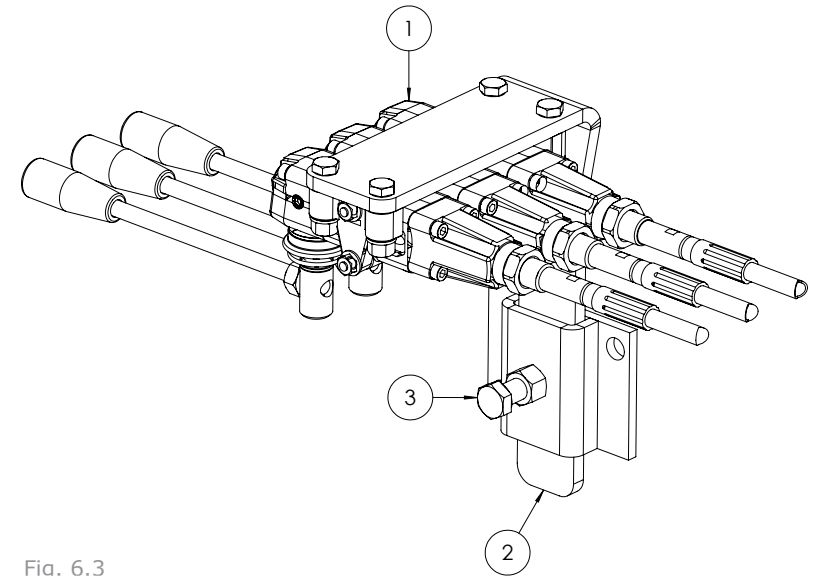

Fig. 6.3

Open/ Closed Centre Hydraulic Systems

The E100 control valve is set as standard for tractors with Open Centre hydraulic systems. To adapt the valve to a closed centre system, replace the Open Centre plug with the longer Closed centre. See 6.4

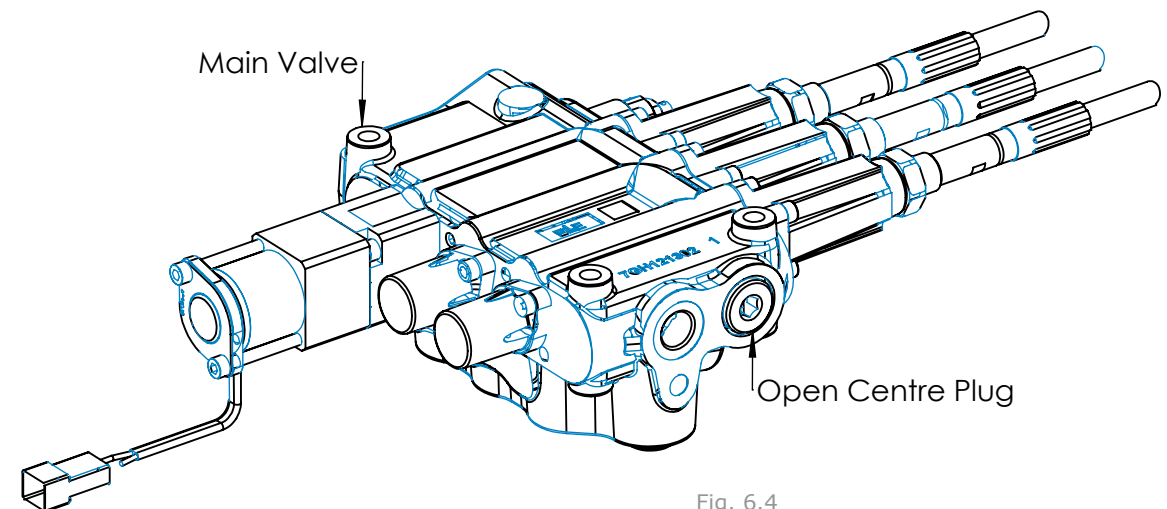

Fig. 6.4

Film cutting Time Adjustment (See Fig 6.5)

The film cutting function is performed automatically when the bale is being tipped off. A valve (1) mounted on the tipping frame is activated by link (3). This link is also connected to the chassis with bolt (2). The point during tipping where the cutter closes can be adjusted by moving the bolt to a different hole on the link. Do not fully tighten this bolt, allow for movement of the link. The film should be fully gathered on the cut and start frame when the cutter closes.

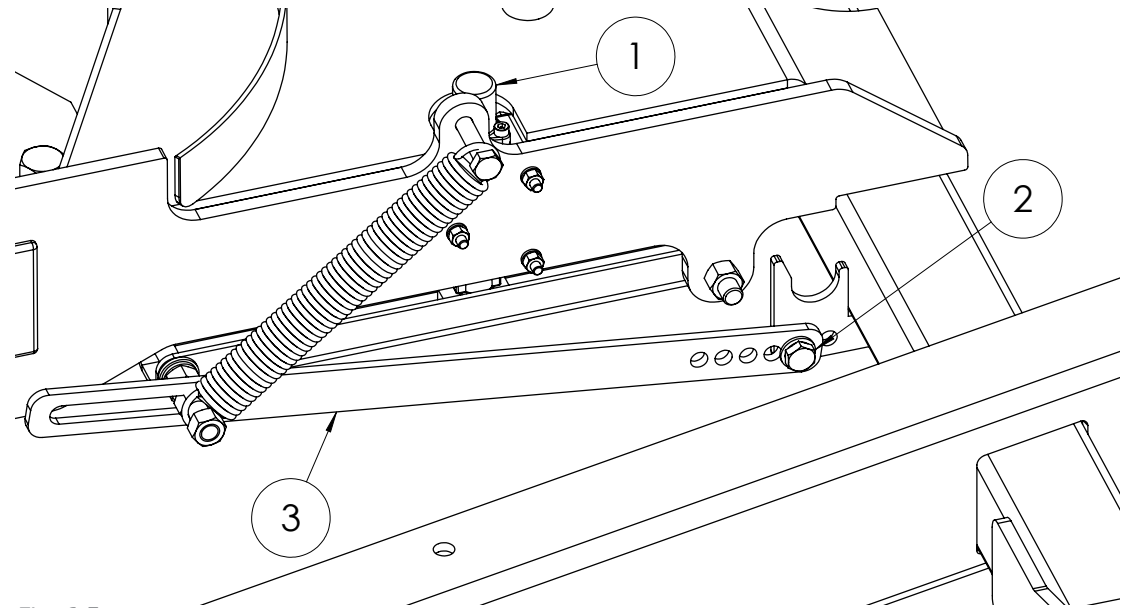

Fig. 6.5

Mounting of Plastic Film (See Fig. 6.6 & 6.7)

When loading a plastic roll, first ensure the Top Cone is pushed up to the latched position, then push back the Dispenser Insert until held in position by the Bottom Latch.

Place the Roll on the Bottom Cone and release the Top Latch.

 BEWARE OF FINGERS!

Pull the film between the rollers on the Dispenser Insert in the direction of the arrow, as shown below. (See also the sticker on the dispenser).

Release the Bottom Latch and allow the rollers to lie against the roll of film.

Pull the film from the roll and tie it to the bale.



Fig. 6.6

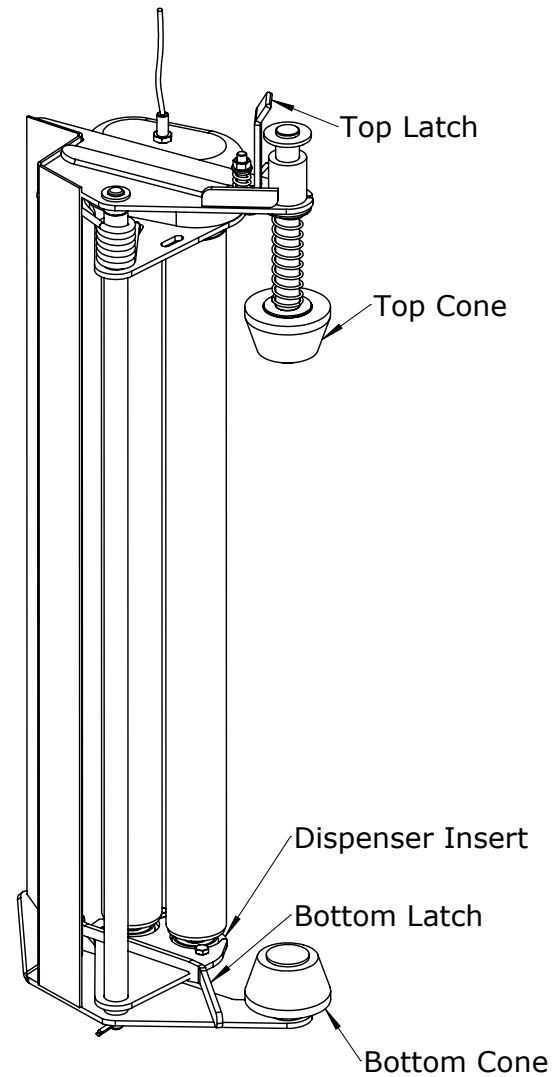

Tanco Dual Stretch Dispenser

All Tanco Autowrap machines are supplied with a patented dual stretch gear system. This system enables a quick change of stretch levels on the Film Dispenser.

If the Gear Bolt is fitted in Position 1 (See Fig. 6.8), the top set of gears provide the stretch @ 70%. By removing the Gear Bolt from Position 1 and fitting it in Position 2, the bottom set of gears become the stretch gears giving 32% (for pre-stretched film) or optionally 55% (for use in hotter climates or with square bales).

Tanco Dispenser Gear Combinations

Inner Gear	Outer Gear	% Stretch
60 Tooth	35 Tooth	70%
58 Tooth	37 Tooth	55%
54 Tooth	41 Tooth	32%

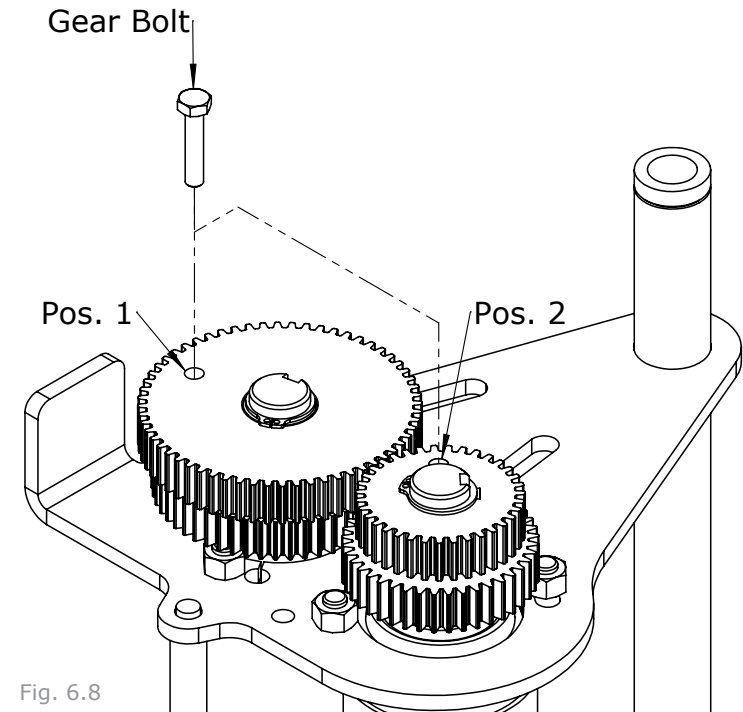

Fig. 6.8

Support Rollers

To allow for stability of the bale during the wrapping process the support rollers can be adjusted different sized bales. It is important that the support rollers are adjusted so that the bale is in the middle of the table. When the bale is on the table (See Fig. 6.9) the distance between the ends of the bale and the support rollers (D) should be $<50\text{mm}$.

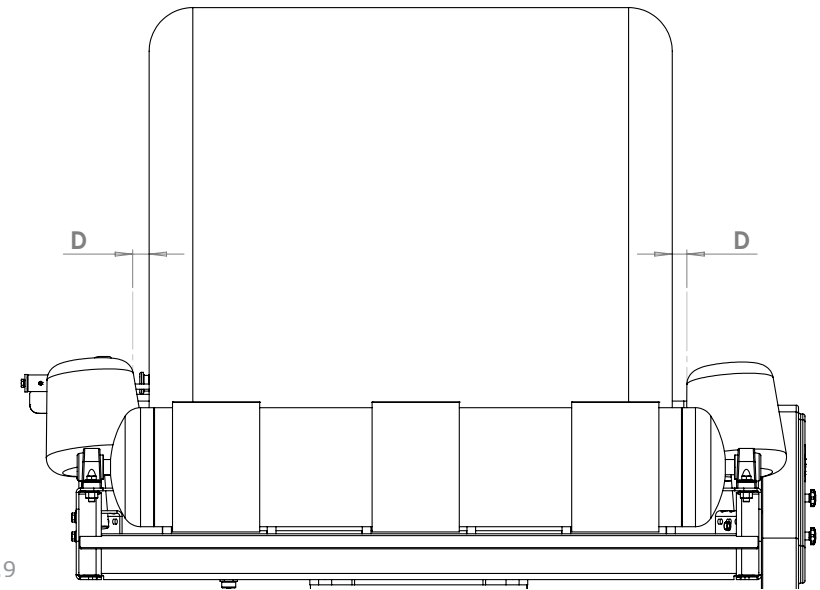

Fig. 6.9

Support Roller Adjustment (See Fig. 6.10)

The support rollers have three adjustment positions (3). In order to move the support roller (1) disconnect the locking bolt (2) from its original position and move the roller to adjust to distance D. Once the roller is in its desired position fix it in place with the locking bolt (2).

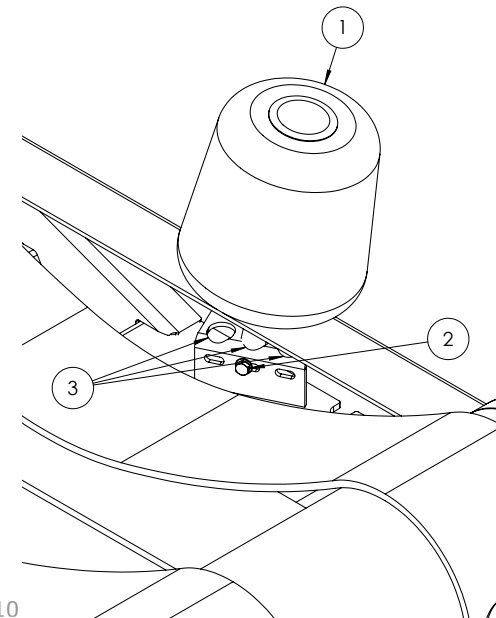

Fig. 6.10

Chain Tensioning (See Fig 6.11)

The roller drive chain is located inside the plastic guard.

To adjust the chain tension loosed the bearing mounting bolts (2). Use the adjusting screw (4) to move the bearing and so adjust the chain tension. Retighten the bearing mounting bolts. Measure the distance from the bearing to the edge of turntable end-plate, check that this measurement is the same on the opposite end of the roller, if not adjust the second bearing.

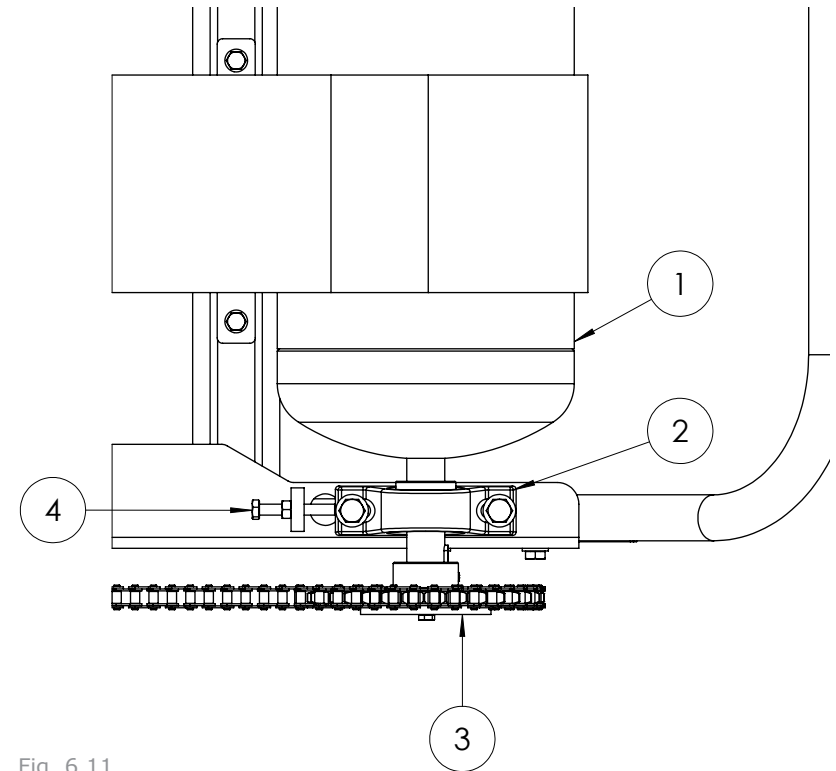

Fig. 6.11

Swivel Axle - Working Position

The right hand wheel has two fixing positions (See Fig. 6.12 & 6.13). The wide position is used in the field to give good stability for loading. The narrow position is used to reduce the overall width of the machine for road transport.

To change the wheel position from working position (P1) to the transport position (P2), remove the Linch pin from the locking pin (4). Rotate the wheel so the wheel mounting rotates on pivot pin (3). Refit the locking pin and Linch pin.

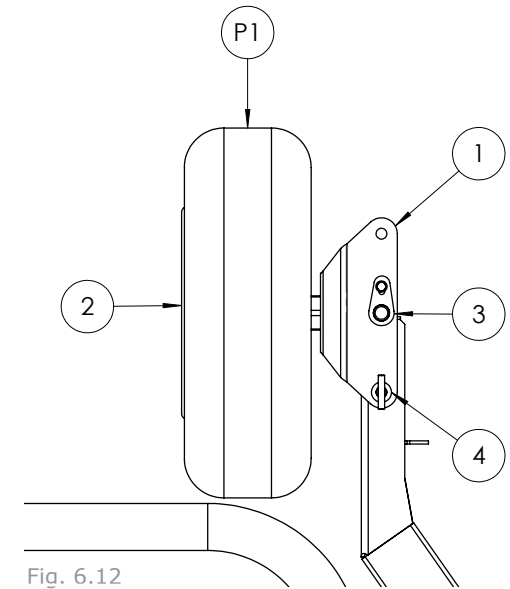

Fig. 6.12

Once the wheel has been rotated to its' working position (P2) Refit the locking pin and Linch pin.

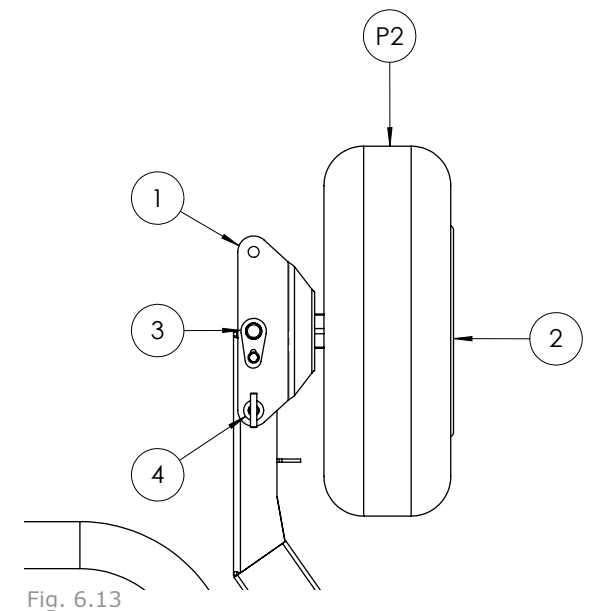

Fig. 6.13

Table Stop Adjustment (See Fig. 6.14)

The E100 Turntable is fitted with a mechanical locking mechanism that aids finding the correct tipping position and then prevents the table from turning while tipping. Screw (3) can be adjusted to change the height of the of the rocker plate (2). The turntable should pass over the rocker plate when turning forward and the latch (1) should come against the rocker plate when the table is turning in reverse.

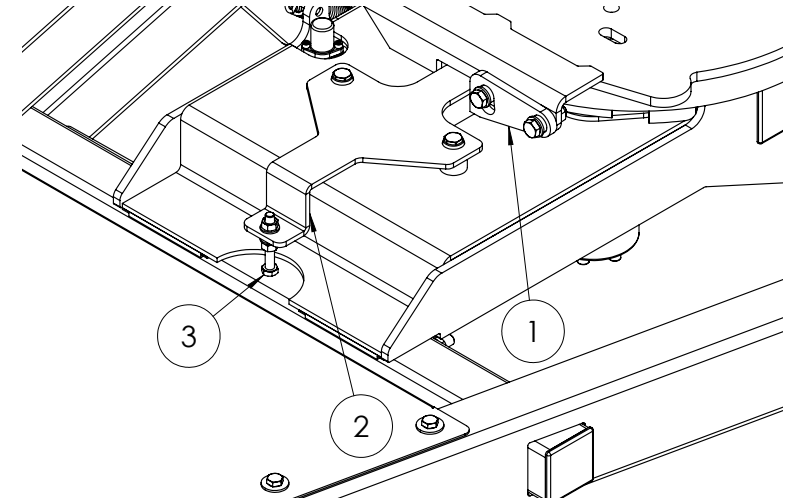

Fig. 6.14

Cut & Start Accumulator Recharging (See Fig. 6.15)

The Cut & Start Cylinder is attached with an accumulator ball which may require recharging. In the event that recharging is required please follow the following steps;

1. Remove the plug from the port (1) on the cylinder.
2. Connect the hose from a hydraulic hand pump (5) to the cylinder port (1).
3. Charge the cylinder to a pressure of 60 Bar (870 P.S.I)
4. Remove the hose from the cylinder port (1) and refit plug.

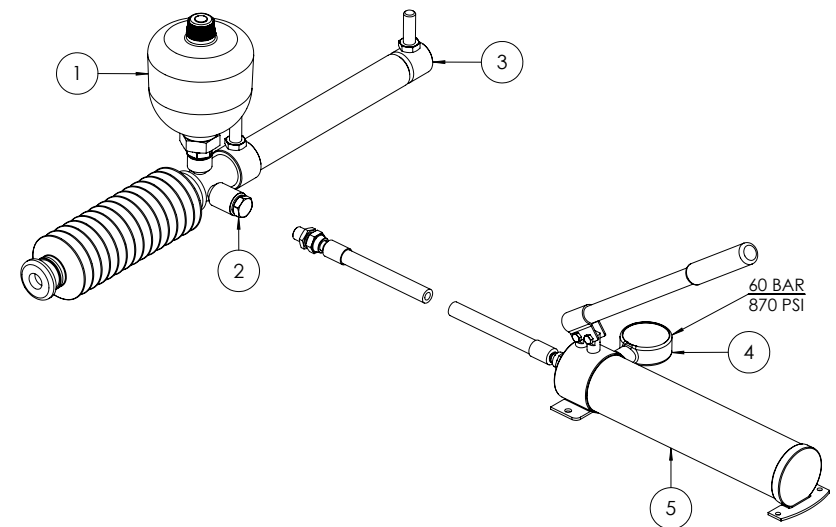

Fig. 6.15

Operational Test

Note: If you are not totally familiar with the operation of the Tanco control system, read this manual in full before proceeding with operational test.

1. Attach the machine to the tractor.
2. Connect the hydraulic feed hose to pressure service coupling on the tractor and the return hose and free return coupling on tractor.
3. Fit controller box inside cap.
4. Connect control box to the machine and connect the 12V power supply.
5. Fit cable control levers in socket in the tractor cab.
6. Lock hydraulic lever in tractor so that oil is flowing through system, set the maximum oil flow from the tractor to 26lt/min. This should give a maximum turntable speed of 30 revolutions per minute.
7. Check function by operating control levers .

- Lift arm up and lift arm down.

NOTE: Ensure the lift arm is down before performing next function.

- Turntable rotation forward and reserve. The turntable should rotate forward at full speed and at slow speed in reverse.

NOTE Ensure that the turntable is parked in the tipping position (Cut and Start to the front) before performing the next function. (It is best to take the turntable slightly past the tip position and then reverse to the stop.

- Tip up, and tip down. When the table nears the top of the tipping position the film Cut and Start should automatically close. This is performed by a linkage operated valve on the tipping frame.

Field Setup

1. Mount the roll of film in the dispenser.
2. Change the load arm safety pin from the transport to the working position.
3. Move the right had wheel from the transport working position.
4. Switch on the controller and set to the desired number of wraps. Typical value shown in the table.

For intermediate sizes count the number of wraps to cover the bale, add one to this number, then multiply by 2 for 4 layers or by 3 for 6 layers. 6 layers are recommended especially for dry or stemmy grass.

Bale Diameter	4 Layers	6 Layers
120cm	16	24
150 cm	20	30

Introduction

The instrument has 6 channel functions with an illuminated 4 digit LCD display, 5 switches to control all functions and an internal alarm. An external alarm is optional. The instrument is normally powered on via the vehicle ignition circuit and recalls the function displayed when the instrument was last used.

What can it do ?

- Continuously displays the current number of wraps around the bale alongside the desired (Target) number of wraps preset by the operator.
- Sounds an alarm at a preset number of wraps before the target number is reached.
- Automatically senses when the bale wrap sequence ends and records it to each of these memory registers:
 - Grand Total
 - Part Total
 - One of eight selectable Store Totals
- Displays the number of bales wrapped per hour, within any desired time period.
- Displays bale wrapping speed in rpm, and sounds an alarm when a preset speed is exceeded.
- Film break alarm and automatic stop.
- Adjustable turntable stop position.

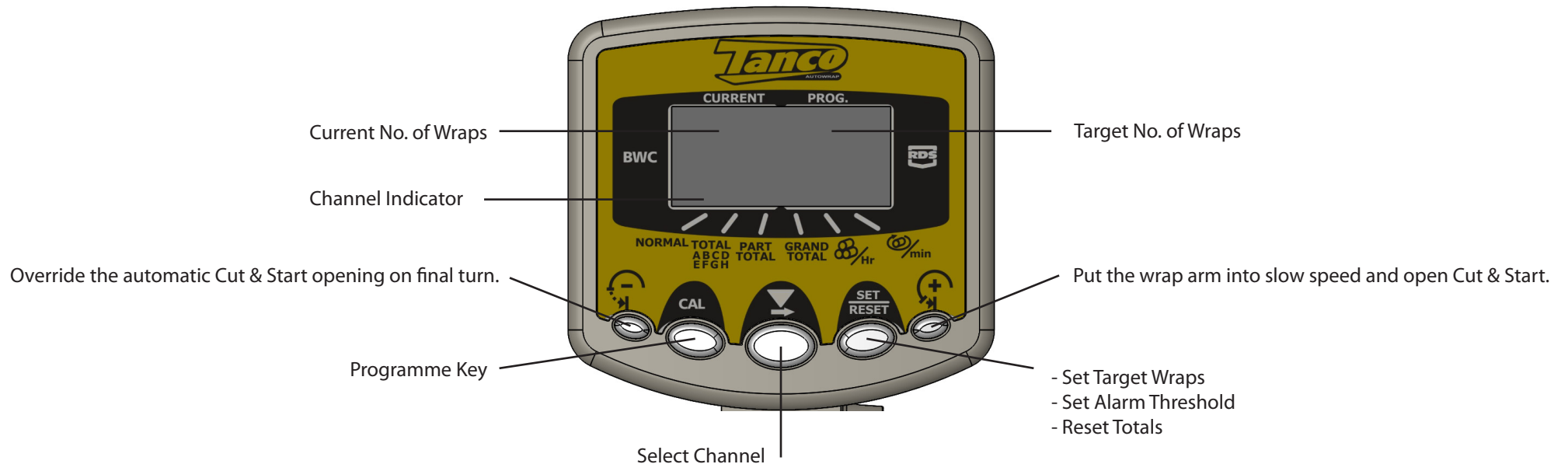

Controller Channels

Channel 1	NORMAL	'Normal' display (Current/Target no. of Wraps)
Channel 2	TOTAL A B C D E F G H	Store Totals (A – H)
Channel 3	PART TOTAL	Part Total
Channel 4	GRAND TOTAL	Grand Total
Channel 5		Bale Wrapping Rate
Channel 6		Bale Wrapping Speed

Channel 1 - Current/Target Wraps Display



The left-hand section shows the current number of wraps and the right hand section shows the target number. When the current number = Target number, the alarm will sound for 2 seconds and the display will flash. (If set, the early warning alarm sounds beforehand). Automatic reset of current number to zero normally occurs 5 seconds after the Target number is reached. If additional wraps are added after the Target number is reached, the current number will continue to advance.

Manually reset No. of Wraps to Zero



Press to select **NORMAL**



Press and hold

Programme the Target Wraps



Hold continuously



...The 3rd digit flashes



Hold to cycle to the required digit then release, otherwise press once...



...The 4th digit flashes



Hold to cycle to the required digit, release all.

Program Early Warning Alarm

An early warning alarm can be programmed to sound from 1 to 9 wraps before the target number is reached. Depending on the setting, the alarm will sound long beeps for up to 8 wraps, short beeps for the final wrap, and then a continuous beep for three seconds. For example, if the bale requires 22 wraps and you want an alarm at 20 wraps, then set the number to 2. To effectively disable the alarm, set the number to 0.



Press to select **@/min**



Hold continuously



...the 4th digit flashes



Hold to cycle to the required digit, release all.

Channel 2 - Store Totals

When bale wrap is complete, one of eight pre-selected memory store totals; A, b, C, d, E, F, G, or H, is automatically advanced by 1. Store totals can be reset individually.

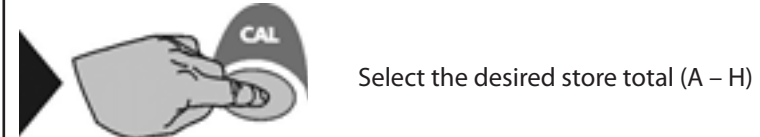
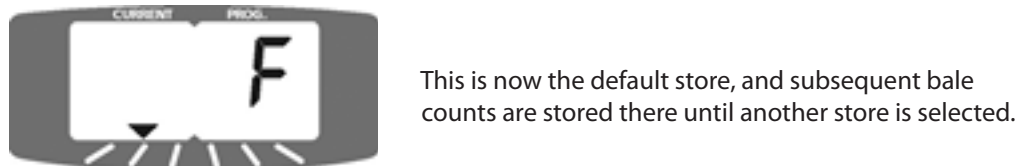
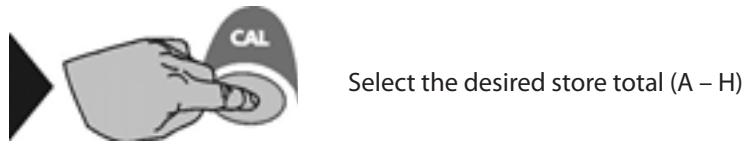
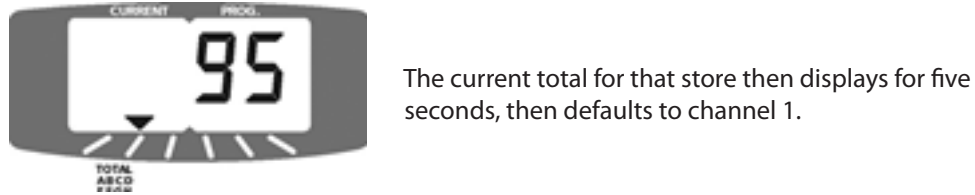
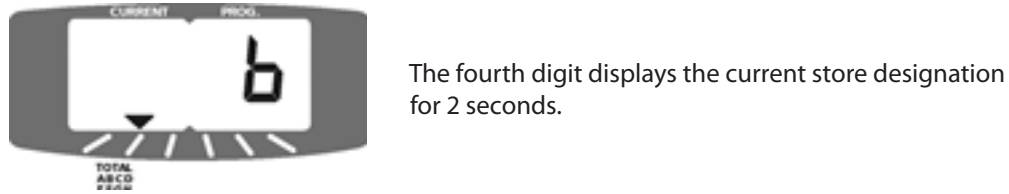

Channel 3 - Part Total

When the bale wrap is complete, the part total is automatically advanced by 1. The part total can be reset at any time

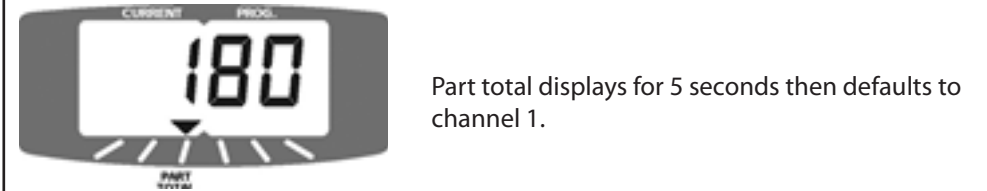

Channel 4 - Grand Total

When the bale wrap is complete, the grand total is automatically advanced by 1. The grand total cannot be reset.

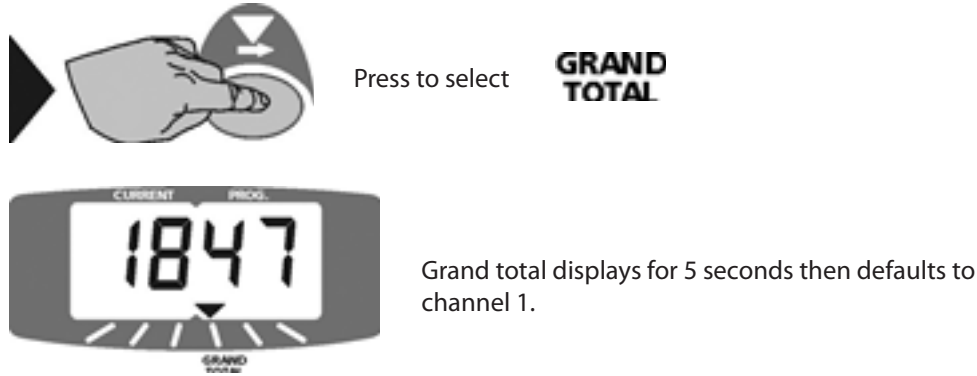

Channel 5 - Bale Wrapping Rate

Displays number of bales wrapped per hour. The time period over which the rate is averaged may be re-started at any time.

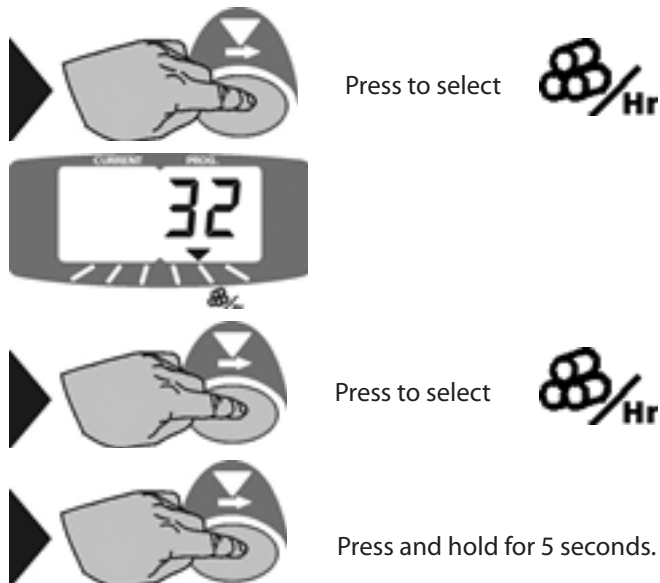

Channel 6 - Bale Wrapping Speed

Displays instantaneous rpm of the bale wrapper at 3 second intervals in the range 10-99 rpm. An overs-speed alarm will sound if the rpm exceeds a pre-programmable limit. The display will default to this channel and flash for the duration of the over-speeding, subsequently reverting to the 'current/target wraps' display.

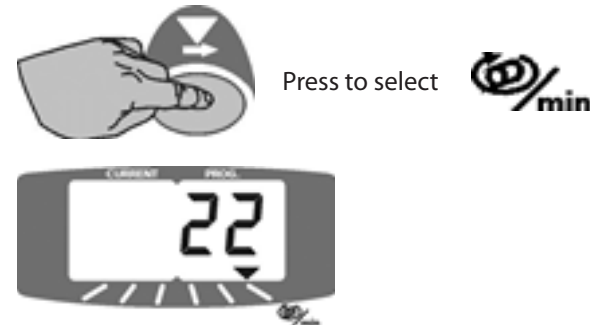

Program the Overspeed Alarm

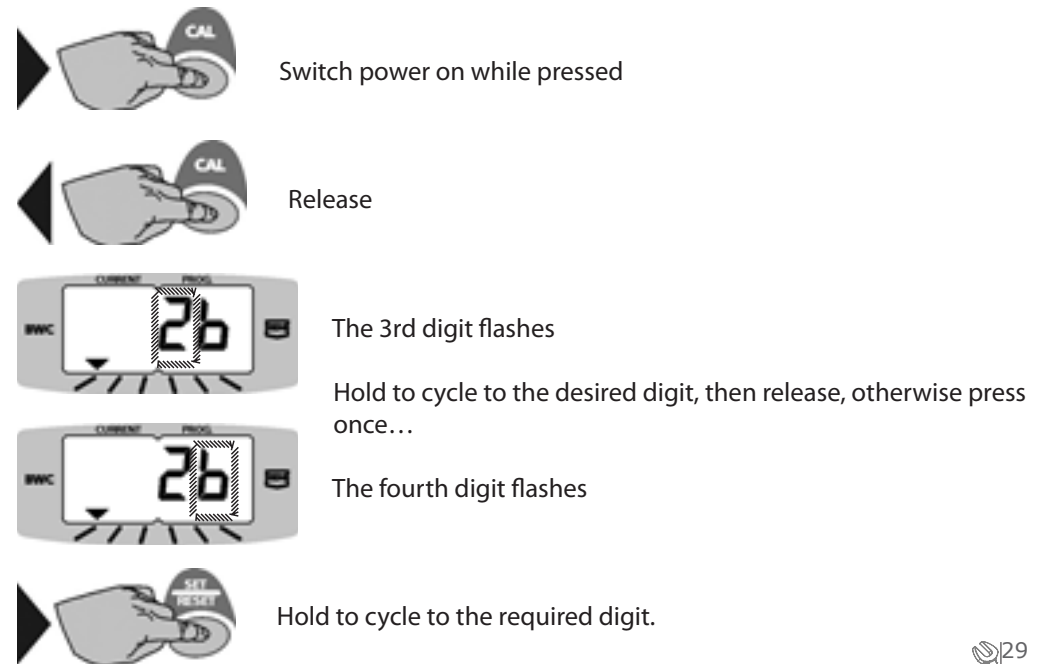

Total Reset

If for some reason the data in the instrument is corrupted or the display shows 'PrOg' then the instrument must be totally reset.

- Switch power off.
- Press and hold all 3 control switches.
- Switch power on.
- Release all switches.

All instrument settings should be returned to the factory-set values. If the display shows 'PrOg' again, the instrument may be faulty and must be returned to the manufacturer for inspection and repair.

Programming Level 2

The 1310 S features Automatic Cut and start operation through the control unit. The 1310 SM also has an autostop feature which holds the joystick in position and automatically releases it at the end of the wrap sequence. The settings of these features are programmable in Level 2.

To enter, cut power and power on while holding CAL button. Release after power on. Press and release CAL to advance chevron to next position

To escape from this calibration level, switch power off and on again.

Channel	Function	Default	Range
1	Over speed Alarm*	35	0-99
2	W – Delay after pulse 2 before X	0.5	0-9.9
3	X – C&S Open duration	0.5	0-9.9
4	Y – Delay after Target – 1 before C&S Open	1.0	0-9.9
5	Z – Duration of C&S Open after Target pulse	2.0	0-9.9
6	V – Autostop release delay	0.7	0.0-9.9

[*In normal operation - If the rotation speed in RPM exceeds this number during operation, the alarm will sound for the duration of this condition. Chevron will default to channel 6 and display will flash in this condition. 0.491 Secs Mark and Space. Chevron will revert to channel 1 when speed drops below overspeed limit].

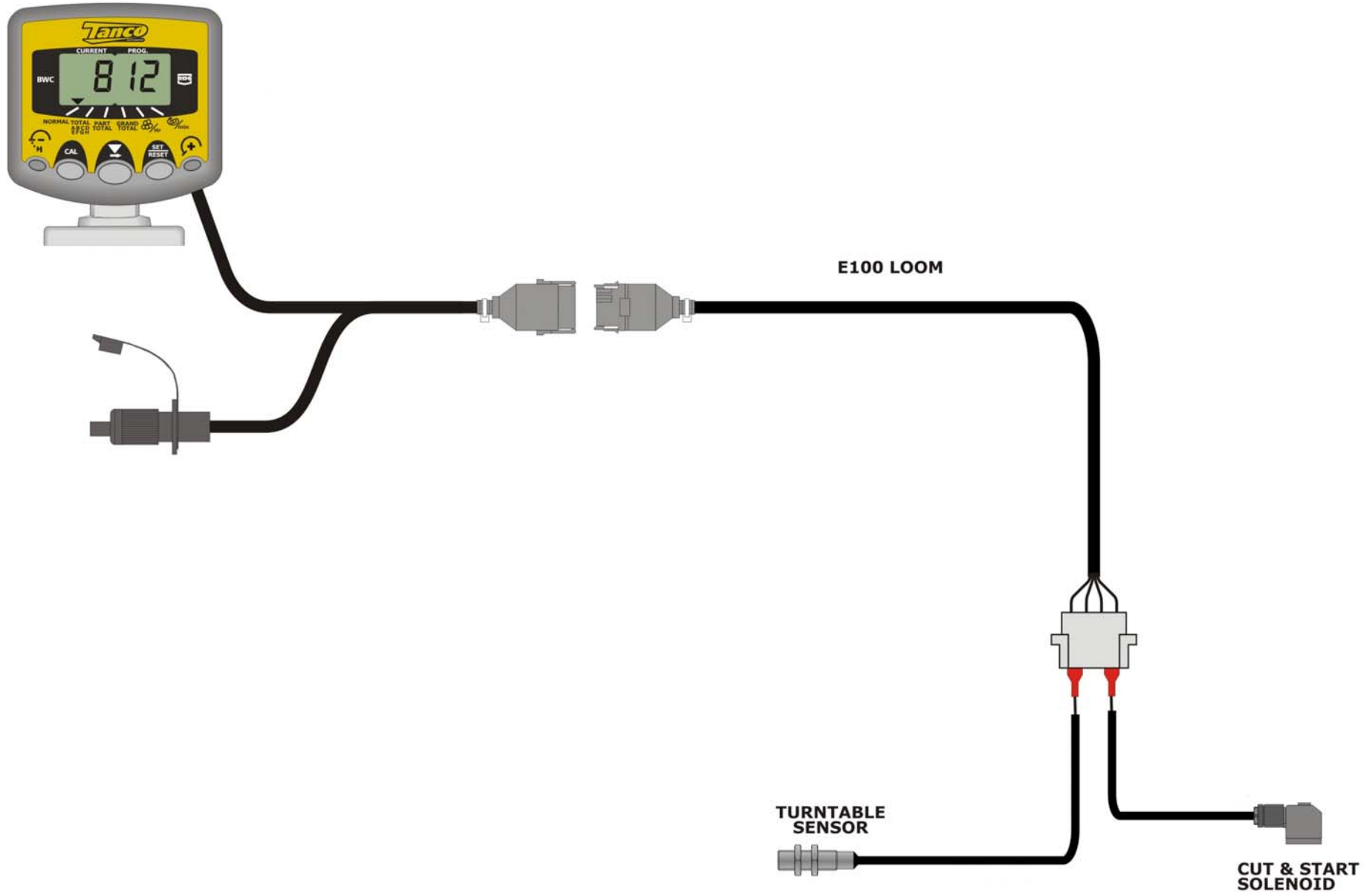

Electro-Hydraulics

Note: There are 3 basics, which must ALWAYS be followed if the machine is to function correctly.

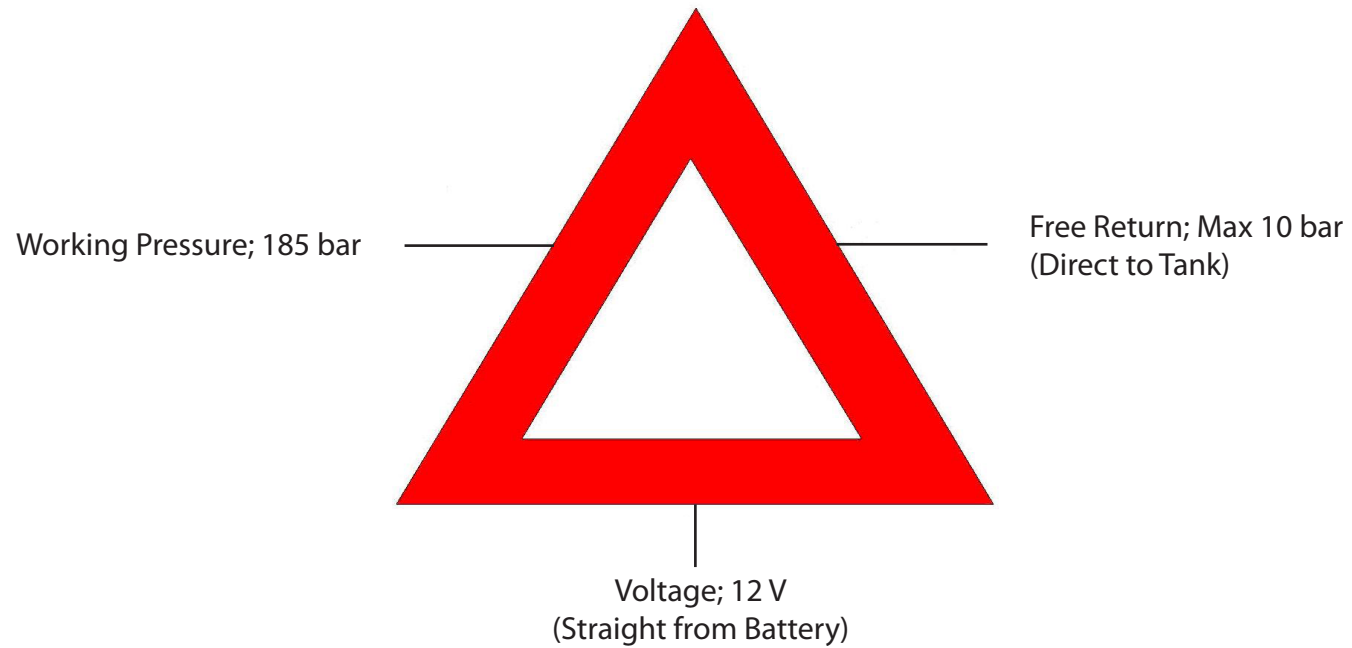

Details of Hydraulics

The E100 machine is controlled by a 3 bank levers and cable operated valve. The levers are mounted in the tractor cab. This valve directly controls the loading, turntable and tipping functions, the remaining function, the film cut and start is automatically activated. The cutter is closed automatically during tipping by a linkage operated diverter valve on the tipping frame. The cutter is automatically opened during wrapping by an electric popper valve activated by the controller.

Control Levers.

Lever 1 operates the Load Arm function, pull the lever to raise the arm, push the lever to lower the arm. Put the Load arm safety pin in the working position before moving the arm.

Note: Make sure the turntable is turned to a position with roller parallel to the load arm before the arm is raised, if it is at an angle the arm can come in contact with the table.

Lever 2 operates the turntable rotation function, pull the lever for forward rotation, push the lever for slow reverse.

Note: Make sure the load arm is the lowered position before the table is rotated.

The E100 has as standard the turntable autostop facility. This means that the turntable lever has only to be held for one revolution of the turntable, after that the lever is held engaged electrically by the control unit. It will automatically release the lever when the pre-set number or wraps is reached. The autostop can be overridden and the turntable stopped at any time by pushing the lever back into the central position.

Lever 3 operates the turntable tipping function. Pull to tip, push to lower.

Note: Make sure the turntable is in the correct tipping position before attempting to tip. If the table is at an angle it can come in contact with the wheel mountings when tipping. The tipping position for the turntable is when the cut and start is to the front. It is best to take the turntable slightly past the tip position and then reverse slowly to the stop. The turntable stop prevent it being turned when tipped.

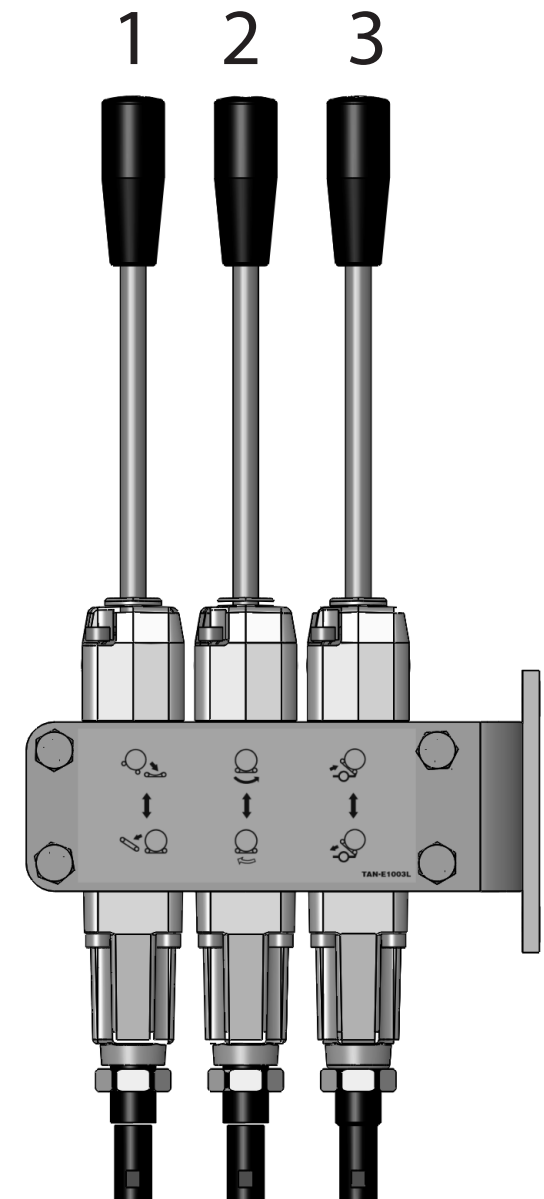
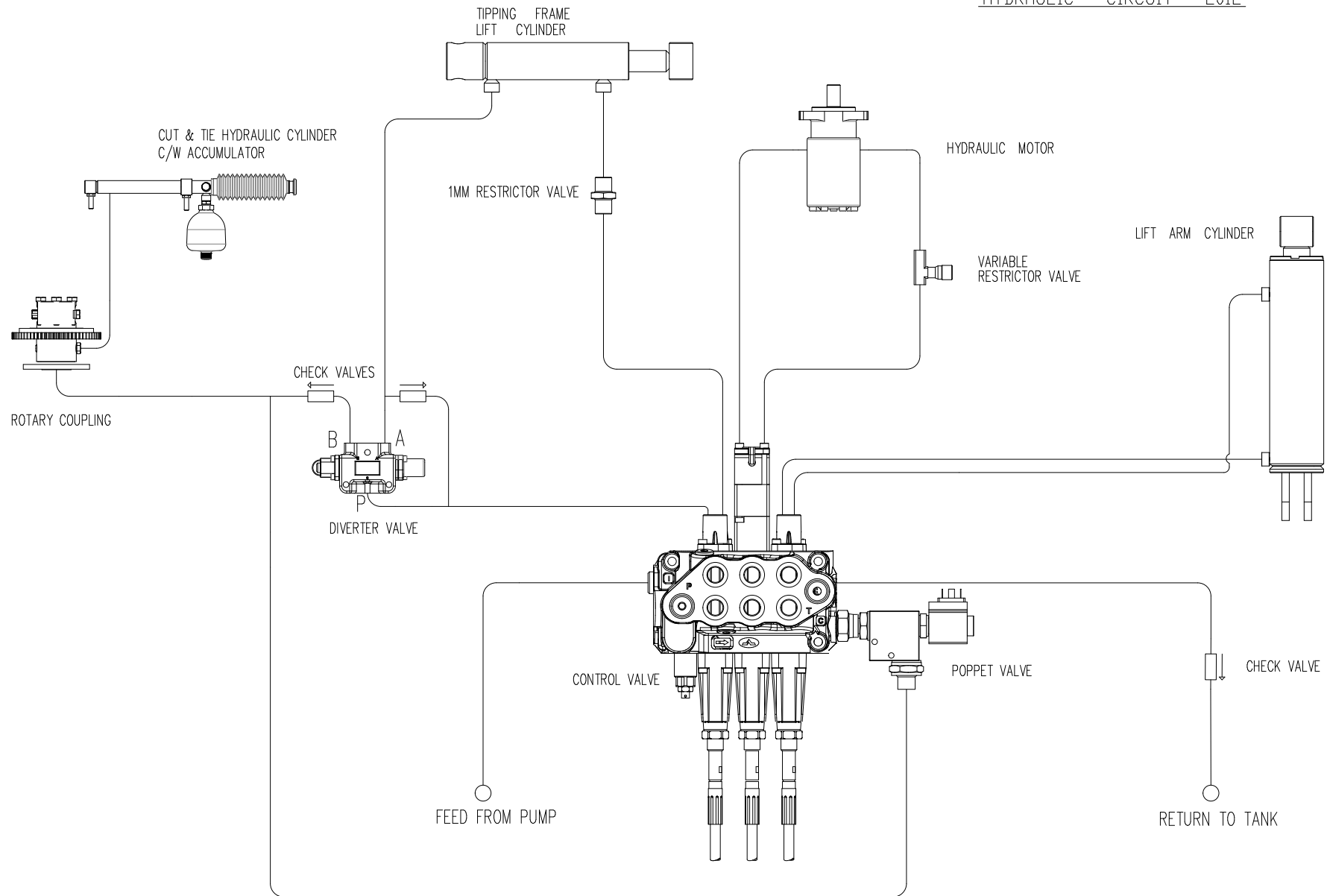
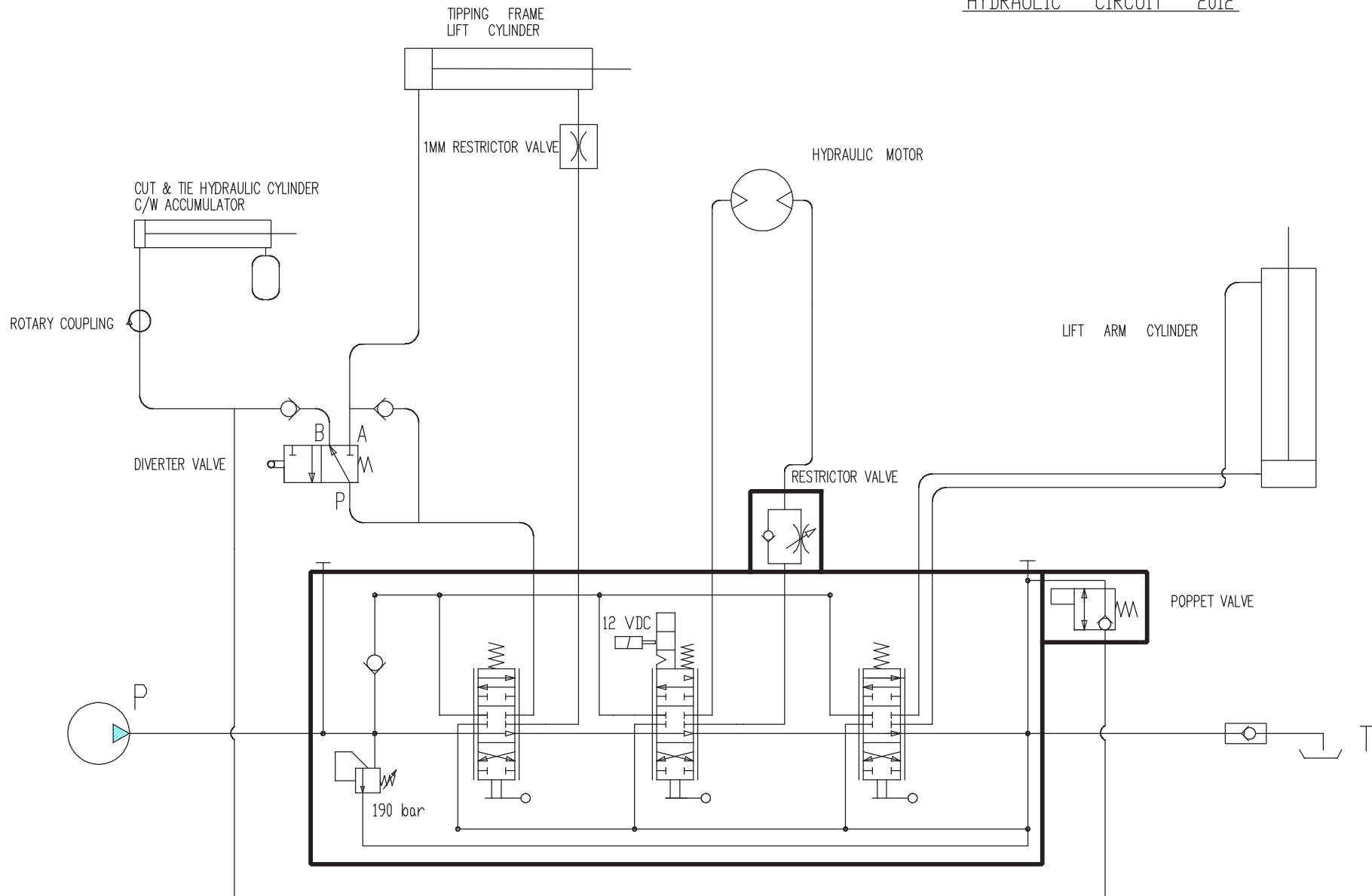

Fig. 8.1

TANCO AUTOWRAP E100 MODEL
HYDRAULIC CIRCUIT 2012



TANCO AUTOWRAP E100 MODEL
HYDRAULIC CIRCUIT 2012



Turntable speed control.

There is no flow control valve on the E100 to limit the turntable speed. The hydraulic flow from the tractor must therefore be limited to a maximum of 26lt/min to prevent the turntable going over the 30 revolutions per minute limit. The controller monitors the table speed and will sound an overspeed alarm if the limit is exceeded.



Check Points Prior to Troubleshooting

There are some general check points that have to be examined first if something is wrong with the machine. There are three basic assumptions that have to be fulfilled for the machine to function properly;

1. The oil pressure from tractor should be 180 bar.
2. The return flow of oil has to be as free as possible, max. 10 bar counter pressure.
3. Enough electric power to all functions.

Oil Pressure

In order to check that the oil pressure into the machine is high enough, a gauge may be applied to the oil pressure hose, for example on the quick coupler. If the pressure is less than 180 bar, there will be less power for the functions. The first place you trace this is at the ROLLERS OUT / IN.

Oil Flow

The amount of oil that the tractor delivers should be minimum 15 liters/minute for satisfactory operation of the machine, but it is recommended that it is 25 liters/minute.

Note: (Max. allowed oil amount is 40 liters/minute). Ensure that oil level in tractor's hydraulic system is correct and tractor's oil filter is changed regularly. REMEMBER! Large oil amount will mean that the Valves get hot. (Small Oil Tank will mean insufficient cooling).

Return Pressure

The return pressure can be too high. With high return pressure the machine's functions will get less power. High return pressure means also that you need more power to operate the valves. MAX. ALLOWED RETURN PRESSURE IS 10 BAR. We recommend "free return" directly to the tank.

Electric Power

It is important to check that all functions receive enough electric power. If not, some, or all functions may fail.

PLEASE CONTACT YOUR DEALER IF YOU ARE IN DOUBT ABOUT ANYTHING.

(Remember always to give your dealer the serial number and production year of your machine when contacting dealer and when ordering spare parts).

Procedure of Troubleshooting

If the machine fails to operate correctly it must be determined if the problem is Hydraulic, Mechanical or Electrical.

Area	Problem	Remedy
Hydraulic	Oil supply under high pressure immediately the tractor hydraulic lever is engaged.	Hydraulic feed or return couplings not properly engaged. Hydraulic couplings connected to a double acting supply on the tractor and supply is in the wrong direction. This can cause the poppet in the return coupling to lock closed. The coupling will have to be loosened to relieve the locking pressure between the check valve and the coupling.
Controller	Controller does not power up.	Check the switch on the back of the controller. Make sure the 3 pin power supply plug is securely connected. There are two 10A fuses in the 3 pin plug, check the condition of these.
	Controller not counting turntable revolutions	Check the turntable magnet and the sensor located on the chassis. Check the controller communication cable is connected and not damaged. Note if the table revolutions are not being counted then the Autostop and the automatic film release will not function.
	Turntable Autostop is not holding lever	The Autostop should hold the turntable lever engaged after 1 revolution of the turntable. Check the electric supply to the Autostop electromagnet. Check the turntable control cable adjustment to make sure it is pushing the valve spool fully to the electromagnet. Adjust cable if necessary.
Film Cut and Start	Cylinder does extend to cut the film when tipping.	Check operation of diverter valve on tipping frame. The spool in the valve should spring out when the link is pulled during tipping.
	Cylinder only partially extends.	The oil pressure in the accumulator is over 60 Bar usually caused by leaking cylinder seals. Get this checked by a service engineer. Check operation of diverter valve on tipping frame.
	Cylinder does not retract to release the film during wrapping.	This cylinder is opened by the oil held under pressure in the accumulator. If the pressure is too low it will not open. Recharge the accumulator. The electric poppet valve that activated by the controller is not opening. It should start opening on the second (adjustable) table revolution and stay open for 3 (adjustable) seconds. Check the wiring to the valve.



Area	Problem	Remedy
Film Cut and Start contd.	Cut and start is closed before film is gathered	The diverter valve on the tipping frame is activated too soon. Change the bolt to a lower hole in the link.
	Bale is tipped off before film is cut.	Diverter valve is activated too late. Move the bolt to a higher hole in the link.
	Film is not cut cleanly	Check condition of blade.
Film Dispenser	Film not wrapping evenly on to bale.	Adjust the film dispenser height so the centre of the film is in line with the centre of the bale.
	Film breaking while wrapping.	Check for damage on the roll of film. Check for damage on the film dispenser rollers. Check film dispenser gears are rollers are rotating freely.
Wrapping	Drive roller and bale not turning.	Check the shear bolt on the driver roller sprocket. If sheared replace with an M8 X30 grade 8.8 bolt.

Periodic Maintenance

Bearings

All ball-bearings are packed with grease, and do not need any more maintenance.

Pre-Stretcher

If the machine is in daily use, the Gears under the plastic cover on the dispenser should be greased with P.T.F.E. based grease to gears every 50hrs..

Cutter / Film Holder

The cutter / film holder is pre-adjusted from the factory and does not need further adjustments. When replacing spare parts, it is necessary to adjust it.

Cleaning

The machine should be cleaned and oiled regularly and at the end of the wrapping season.



When using high pressure washing apparatus, care must be taken with the electrical installation.

Also make sure that water is not sprayed directly into the bearings, etc. Keep the control box protected from rain and water. If necessary use compressed air to dry electrical components.

Hydraulic Cylinders

Make sure that all hydraulic cylinders are closed when storing the machine.

Quick Couplers

Ensure that the quick couplers are kept clean and apply the dust caps after use.

Storage

The machine should be parked on a dry place during the closed season.

Nut & Bolts

All nuts and bolts should be tightened after the first hour's use, thereafter regularly.

Road Wheels

Wheel pressure should be normally kept at 42 psi depending on bale weight and field conditions.



Lubrication

1. Drive Chain & Sprocket - Grease every 24 hours
2. Drive & Idler Roller Bearings - Grease every 24 hours
3. Lift Arm Pivot Pins - Grease every 24 hours
4. Tip Frame Pivot Pins - Grease every 24 hours
5. Hydraulic Cylinders - Grease every 24 hours
6. Dispenser Gears - Grease every 24 hours
7. Gearbox (Internal) - Grease every 12months
8. Motor Gear & Gearbox (External) - Grease every 24 hours

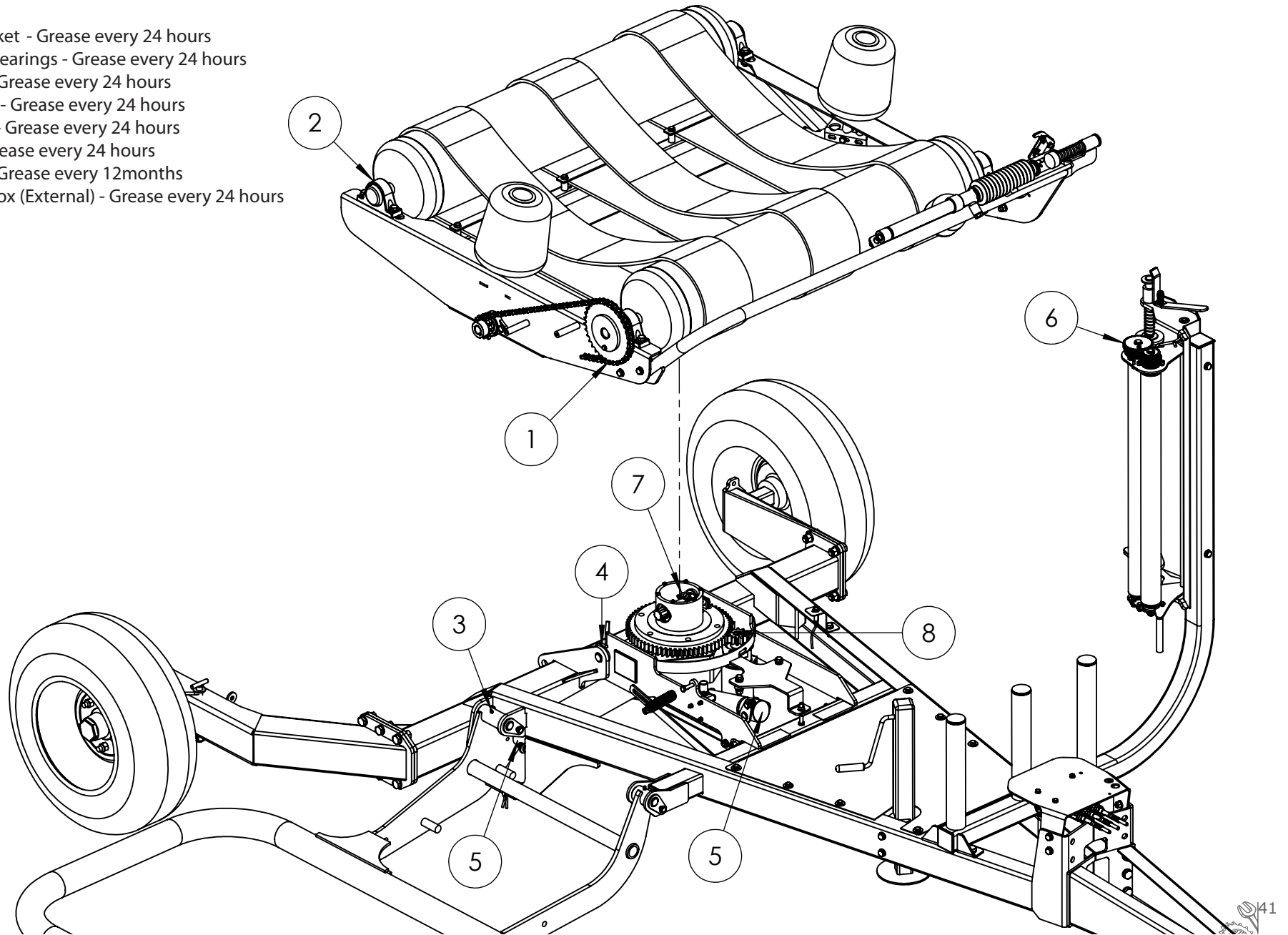

GUARANTEE

Subject to hereunder provided, the sellers undertake to correct either by repair or at their election by replacement any defect of material or workmanship which occurs in any of its goods within twelve months after delivery of such goods to first user, with the exception of contractors or commercial users when warranty period is six months.

In respect of Autowraps the warranty period is for 12 months or 8000 bales, whichever occurs first.

The term goods when used in this document means the article or articles described in invoices as sold by the sellers but does not include equipment or proprietary parts or accessories not manufactured by the sellers. The sellers, however, undertake to pass on so far as they legally can to the first user the benefit of any warranty given to the sellers by the suppliers of such equipment, parts or accessories.

This understanding shall not apply to:-

- (a) Any goods that have been sold by the first user.
- (b) Any goods which have been injured by unfair wear and tear, neglect or improper use.
- (c) Any goods the identification marks of which have been altered or removed.
- (d) Any goods that have not received the basic normal maintenance such as tightening of bolts, nuts, tines, hose connections and fittings and normal lubrication with the recommended lubricant.
- (e) The use of any product on tractors exceeding the recommended horsepower.
- (f) Any goods that have been altered or repaired other than on instruction or with the written approval of the seller or to which any part not manufactured or having written approval by the sellers have been fixed.
- (g) Any second-hand goods or parts thereof.

Any allegedly defective part or parts returned to the seller must be sent carriage paid. No claim for repair or replacement will be entertained unless upon discovery of the alleged defect written notification is sent to the Sellers giving, at the same time, the name of the Buyer from whom the goods were purchased and the date of purchase, together with the full details of the alleged defect and the circumstances involved, also the serial number of the machine etc.

The sellers shall be under no liability to their Buyers and first or subsequent users of their goods or to any other person or persons for loss or damage howsoever arising in respect of either personal injuries or for arising out of, or in any other way connected with or arising from the manufacture, sale, handling, repair, maintenance, replacement or use of its goods or the failure or malfunction of any of its goods.

Representation and/or warranties made by any persons (including Buyers and employees and other representatives of the Seller) which are inconsistent or conflicting with these conditions are not binding upon the sellers unless given in writing and signed by a director of sales.

CLAIMS

If you wish to make a claim under the guarantee:

1: Immediately, stop using the machine.

2: Consult with your Tanco dealer (supplier). He/She can download a warranty claim form on-line. This should be filled out and e-mailed to distributor and forwarded to relevant contact person in Tanco. Please ensure all relevant information is included on this form

3: Consult with your Tanco dealer (supplier) and have him forward your claim and the damaged item to Tanco.

EC DECLARATION OF CONFORMITY

ACCORDING TO DIRECTIVES 2006/42/EC

Manufacturer:
Tanco Autowrap Ltd
Bagenalstown
Co. Carlow
IRELAND



CERTIFIES THAT THE FOLLOWING PRODUCT:

TANCO AUTOWRAP
MODEL: E100 SA Autowrap
SERIAL NO: D13-250 - D13-350

To which this declaration relates, corresponds to the essential requirements of the Directive 2006/42/EC.

To conform to these essential health and safety requirements, the provisions of the following harmonized standards were particularly considered:

ISO 12100, EN 294, prEN 703, EN ISO 13857, EN ISO 4254 - 1, prEN 982.

DATE: 01/11/2011

Signed: *Con Hourihane*
Con Hourihane, Technical Manager

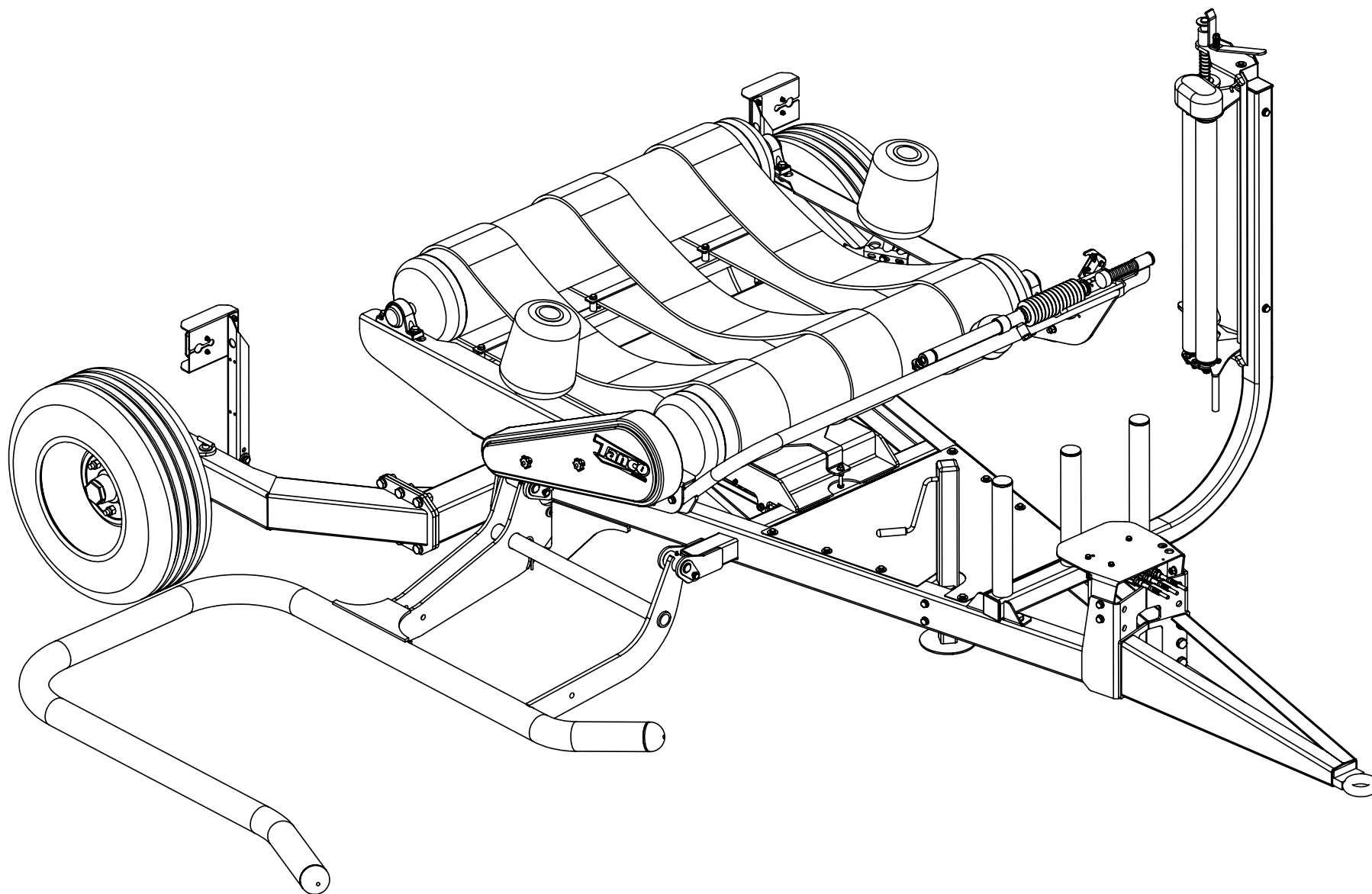

E100 Ersatzteilliste

Wir empfehlen, nur Originalteile als Ersatzteile zu verwenden.

Befolgen Sie bei der Bestellung von Ersatzteilen bitte die folgenden Schritte:

1. Stellen Sie anhand der detaillierten Zeichnungen fest, welches Teil Sie benötigen.
2. Haben Sie das benötigte Teil identifiziert, geben Sie die Teilnummer auf dem Bestellschein an, mit dem Sie das/die Ersatzteil/e bestellen.
3. Geben Sie bei jeder Bestellung die Serien- und die Modellnummer Ihrer Maschine an.
4. Alle Bestellungen müssen über Ihren Tanco-Händler vor Ort erfolgen und müssen Tanco Autowrap als Fax oder E-Mail erreichen.

E100 Spare Parts List

We recommend that when you require spare parts you use only original parts.

When ordering spare parts please follow the following steps;

1. Identify the part you require using the detailed drawings.
2. Once you have identified the part you require reference the item number relating to the part on the item list where you will find the part number and description of the part you require. You will be require to give the complete part no and decription when ordering your part(s).
3. When ordering you must give the Serial Number and Model Number of the machine.
4. All orders must go through your local Tanco Dealer, and must be either faxed or e-mailed to Tanco Autowrap.

Liste des pièces de rechange E100

Si vous avez besoin de pièces de rechange, nous vous recommandons de n'utiliser que des pièces garanties d'origine.

Pour toute commande de pièces de rechange, veuillez suivre les étapes suivantes :

1. Identifiez la pièce dont vous avez besoin à l'aide des schémas détaillés.
2. Après avoir identifié la pièce dont vous avez besoin, relevez son numéro de référence dans la liste des pièces dans laquelle vous trouverez également la description de la pièce requise. Lors de la commande, vous devez indiquer la référence et la description complètes de la pièce.
3. Lors de la commande, vous devrez mentionner le numéro de série et le numéro de modçle de la machine.
4. Vous devez effectuer toutes les commandes auprès de votre revendeur Tanco local et les faxer ou les envoyer par e-mail à Tanco Autowrap.

KAPITEL CHAPTER CHAPITRE	SEITE PAGE PAGE	BENENNUNG	DESCRIPTION	DESIGNATION
1	4	Fahrgestell-Baugruppe	Chassis Assembly	Châssis
	5	1.1 Feste Achse	1.1 Fixed Axle	1.1 Essieu fixe
	7	1.2 Schwenkachse	1.2 Swivel Axle	1.2 Essieu articulé
	9	1.3 Lastarm	1.3 Load Arm	1.3 Bras de chargement
	11	1.4 Heber- und Vorstreckerbefestigung	1.4 Jack & Dispenser Mounting	1.4 Montage du cric & distributeur
	13	1.5 Ventilbefestigung	1.5 Valve Mounting	1.5 Montage de la vanne
	15	1.6 Anhängenoption	1.6 Hitch Option	1.6 Option d'attelage
2	18	Aufstellrahmen-Baugruppe	Tip Frame Assembly	Assemblage du bâti de basculement
	19	2.1 Befestigung des Aufstellrahmens	2.1 Tip Frame Mounting	2.1 Montage du bâti de basculement
	21	2.2 Getriebebefestigung	2.2 Gear Mounting	2.2 Montage de l'engrenage
	22	2.3 Schneid- und Bindebetätigung	2.3 Cut and Tie Actuator	2.3 Actionneur de coupe et d'attache
3	26	Drehtisch-Baugruppe	Turntable Assembly	Ensemble de table pivotante
	27	3.1 Ballenstützrolle	3.1 Bale Stop Roller	3.1 Rouleau d'arrêt de balle
	29	3.2 Spannrolle	3.2 Idler Roller	3.2 Rouleau-guide
	31	3.3 Antriebsrolle	3.3 Drive Roller	3.3 Rouleau moteur
	33	3.4 Getriebeantrieb	3.4 Gear Drive	3.4 Transmission par engrenages
	35	3.5. Befestigung der Schneid- & Bindebaugruppe	3.5 Cut & Tie Mounitng	3.5 Montage de coupe et d'attache
	37	3.6. Schneid- & Bindebaugruppe	3.6 Cut & Tie Assembly	3.6 Ensemble de coupe et d'attache
4	40	Vorstreckerbaugruppe	Dispenser Assembly	Ensemble Distributeur
	41	4.1 Einsatzbaugruppe	4.1 Insert Assembly	4.1 Insert
	43	4.2 Einsatzbefestigung	4.2 Insert Mounitng	4.2 Montage de l'insert

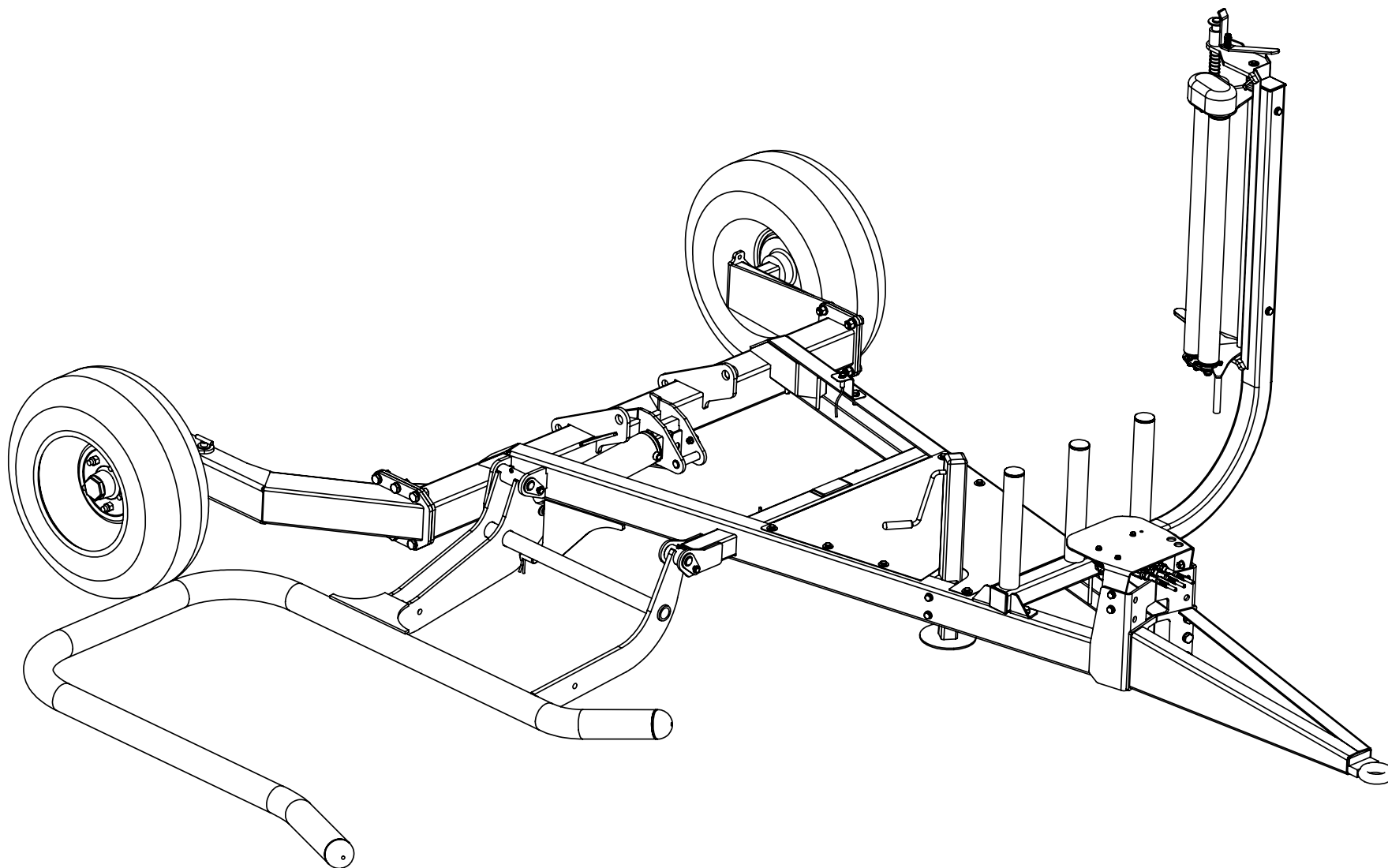

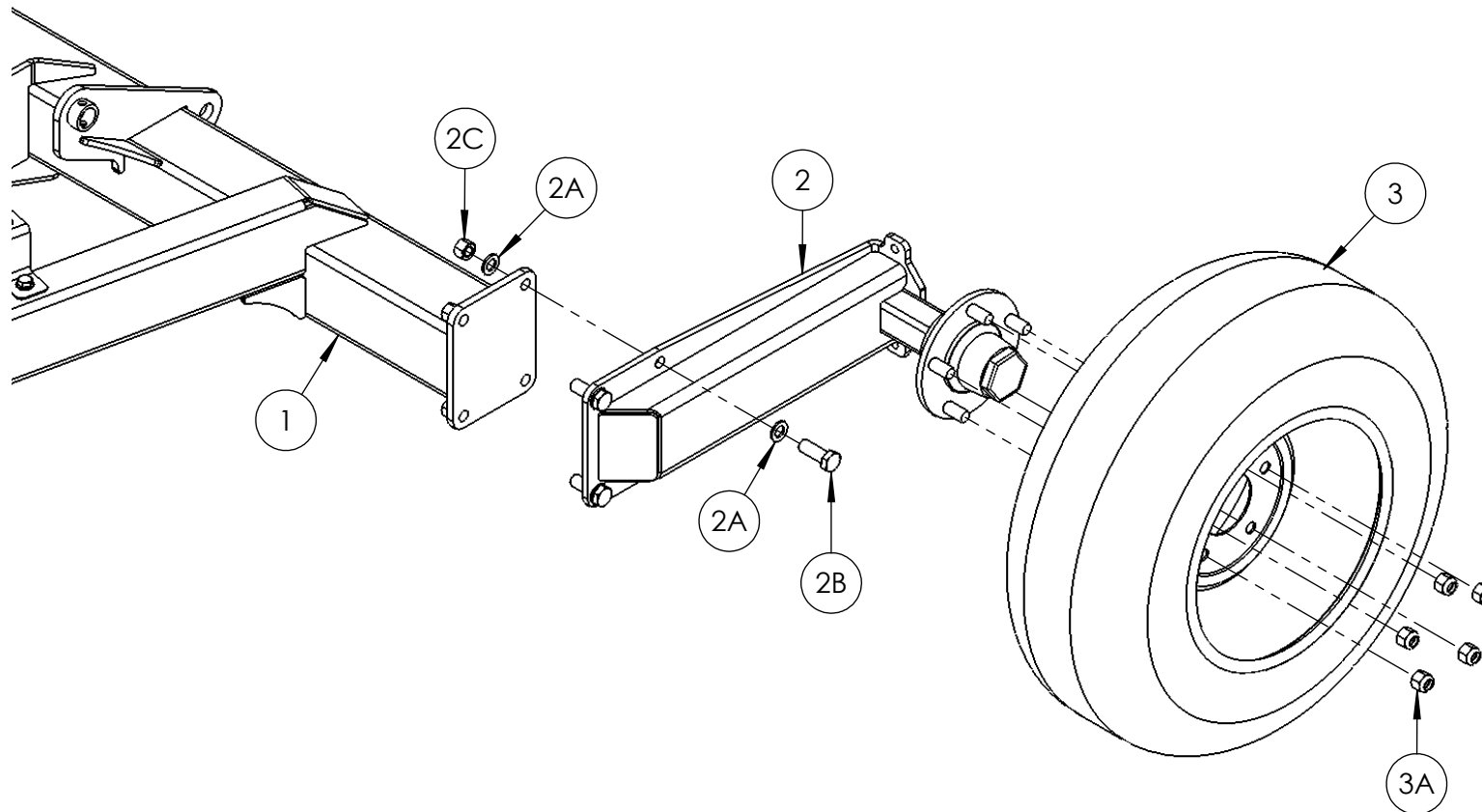

POS. NR.	TEILE NR.	STUCK	BENENNUNG	DESCRIPTION	DESIGNATION	TECHNISCHE ANGABEN
POS. NR.	PART NR.	QUANTITY				TECHNICAL DATA
POS. NO.	PIECE NO.	QUANTITEE				DONNEES TECHNIQUES
1	2001000	1	Fahrgestell	Chassis	Châssis	
2	2001200	1	Feste Achse	Fixed Axle	Essieu fixe	
2A	Z10-02-16	8	Unterlegscheibe	Flat Washer	Rondelle plate	M16
2B	Z26-124S	4	Innensechskantschraube	Hex Set	Vis de régl. Hex	M16 x 50mm
2C	Z23-16	4	Feststellmutter	Locknut	Contre-écrou	M16
3	Z04-03	1	Straßenrad	Road Wheel	Roue de transport	10.0/80-12
3A	M22AWNA	5	Radmutter	Wheel Nut	Écrou de roue	M16

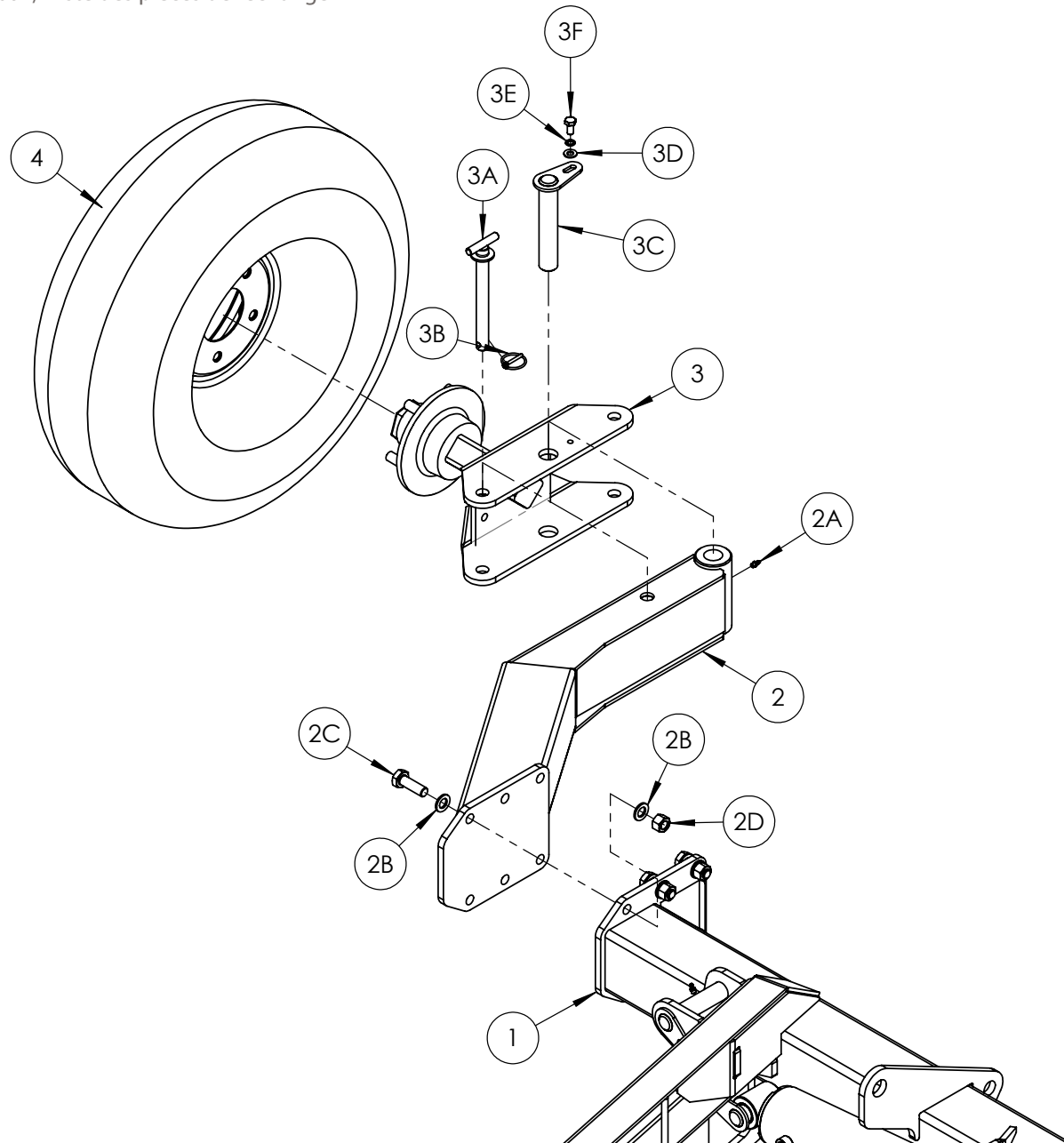

POS. NR.	TEILE NR.	STUCK	BENENNUNG	DESCRIPTION	DESIGNATION	TECHNISCHE ANGABEN
POS. NR.	PART NR.	QUANTITY				TECHNICAL DATA
POS. NO.	PIECE NO.	QUANTITEE				DONNEES TECHNIQUES
1	2001000	1	Fahrgestell	Chassis	Châssis	
2	2001210	1	Schwenkachsenbefestigung	Swivel Axle Mount	Montage de l'essieu articulé	
2A	34060800	1	Schmiernippel	Grease Nipple	Raccord graisseur	M16
2B	Z10-02-16	12	Unterlegscheibe	Flat Washer	Rondelle plate	M16
2C	Z26-124S	6	Innensechskantschraube	Hex Set	Vis de régl. Hex	M16 x 50mm
2D	Z23-16	6	Feststellmutter	Locknut	Contre-écrou	M16
3	2001220	1	Schwenkachse	Swivel Axle	Essieu articulé	
3A	2001570	1	Sicherungsstift	Locking Pin	Goupille d'arrêt	
3B	Z03-22-06	1	Klappsplint	Linch Pin	Clavette d'essieu	Ø7/16"
3C	2001560	1	Gelenkzapfen	Pivot Pin	Axe d'articulation	
3D	Z10-02-10	1	Unterlegscheibe	Flat Washer	Rondelle plate	M10
3E	Z12-02-10	1	Federscheibe	Spring Washer	Rondelle à ressort	M10
3F	Z26-060S	1	Innensechskantschraube	Hex Set	Vis de régl. Hex	M10 x 20mm
4	Z04-03	1	Straßenrad	Road Wheel	Roue de transport	10.0/80-12

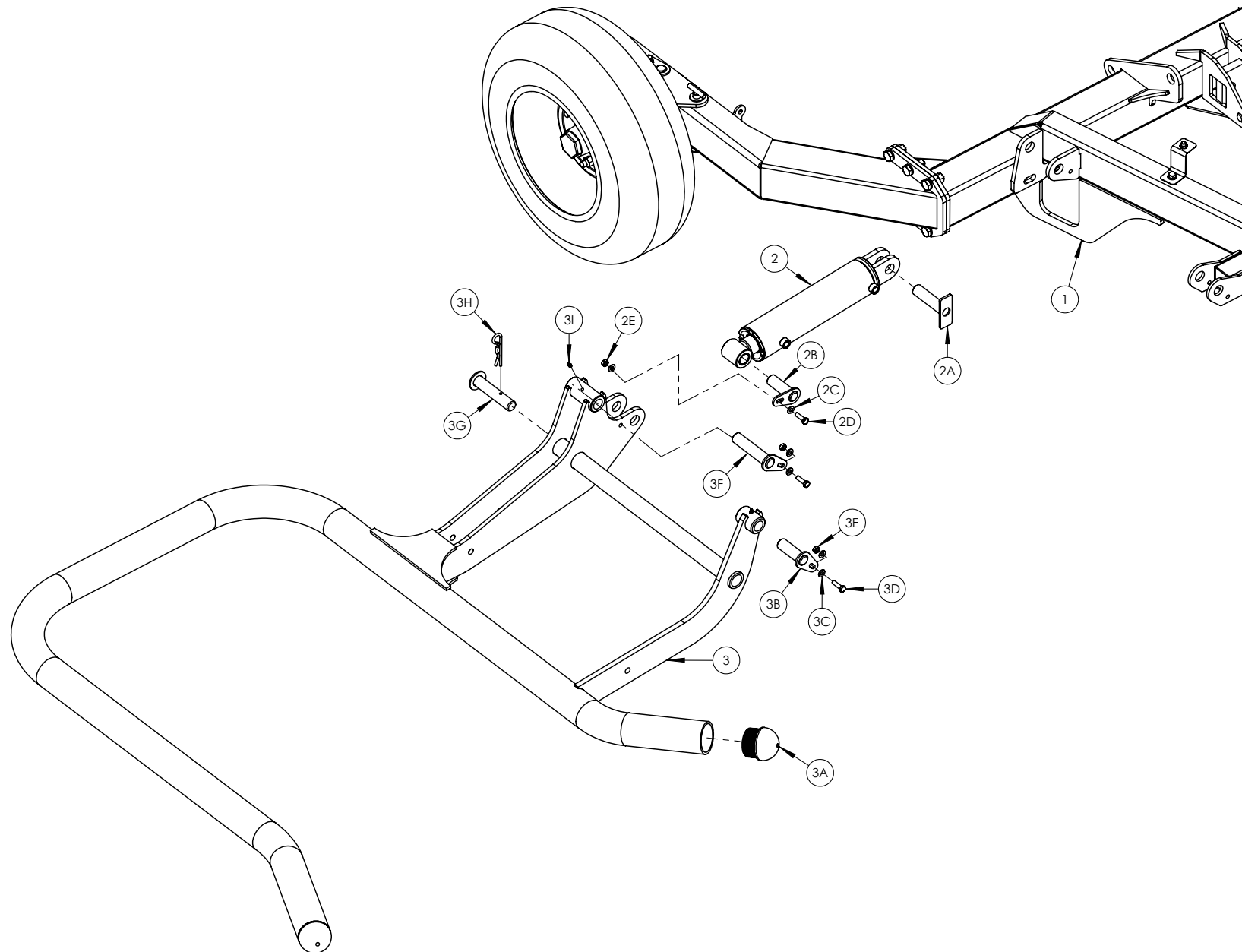

POS. NR. POS. NR. POS. NO.	TEILE NR. PART NR. PIECE NO.	STUCK QUANTITY QUANTITEE	BENENNUNG	DESCRIPTION	DESIGNATION	TECHNISCHE ANGABEN TECHNICAL DATA DONNEES TECHNIQUES
1	2001000	1	Fahrgestell	Chassis	Châssis	
2	2008020	1	Zylinderstift	Cylinder Pin	Axe du vérin	
2A	2001525	1	Zylinderstift	Cylinder Pin	Axe du vérin	
2B	2001510	1	Gelenkzapfen	Pivot Pin	Axe d'articulation	
2C	Z10-02-10	2	Unterlegscheibe	Flat Washer	Rondelle plate	M10
2D	Z26-063S	1	Innensechskantschraube	Hex Set	Vis de régl. Hex	M10 x 35mm
2E	Z23-10	1	Feststellmutter	Locknut	Contre-écrou	M10
3	2004000	1	Lastarmgestell	Load Arm Frame	Bâti du bras de chargement	
3A	Z32-23	2	Rohrschutzkappe	Tube Cap	Bouchon de tube	Ø3"
3B	2001510	1	Gelenkzapfen	Pivot Pin	Axe d'articulation	
3C	Z10-02-10	4	Unterlegscheibe	Flat Washer	Rondelle plate	M10
3D	Z26-062S	2	Innensechskantschraube	Hex Set	Vis de régl. Hex	M10 x 30mm
3E	Z23-10	2	Feststellmutter	Locknut	Contre-écrou	M10
3F	2001520	1	Gelenkzapfen	Pivot Pin	Axe d'articulation	
3G	2001535	1	Sicherheitsstift	Safety Pin	Goupille de sécurité	
3H	Z36-03	1	Haltebügel	R' Clip	Clip « R »	Ø6mm
3I	34060800	2	Schmiernippel	Grease Nipple	Raccord graisseur	M8



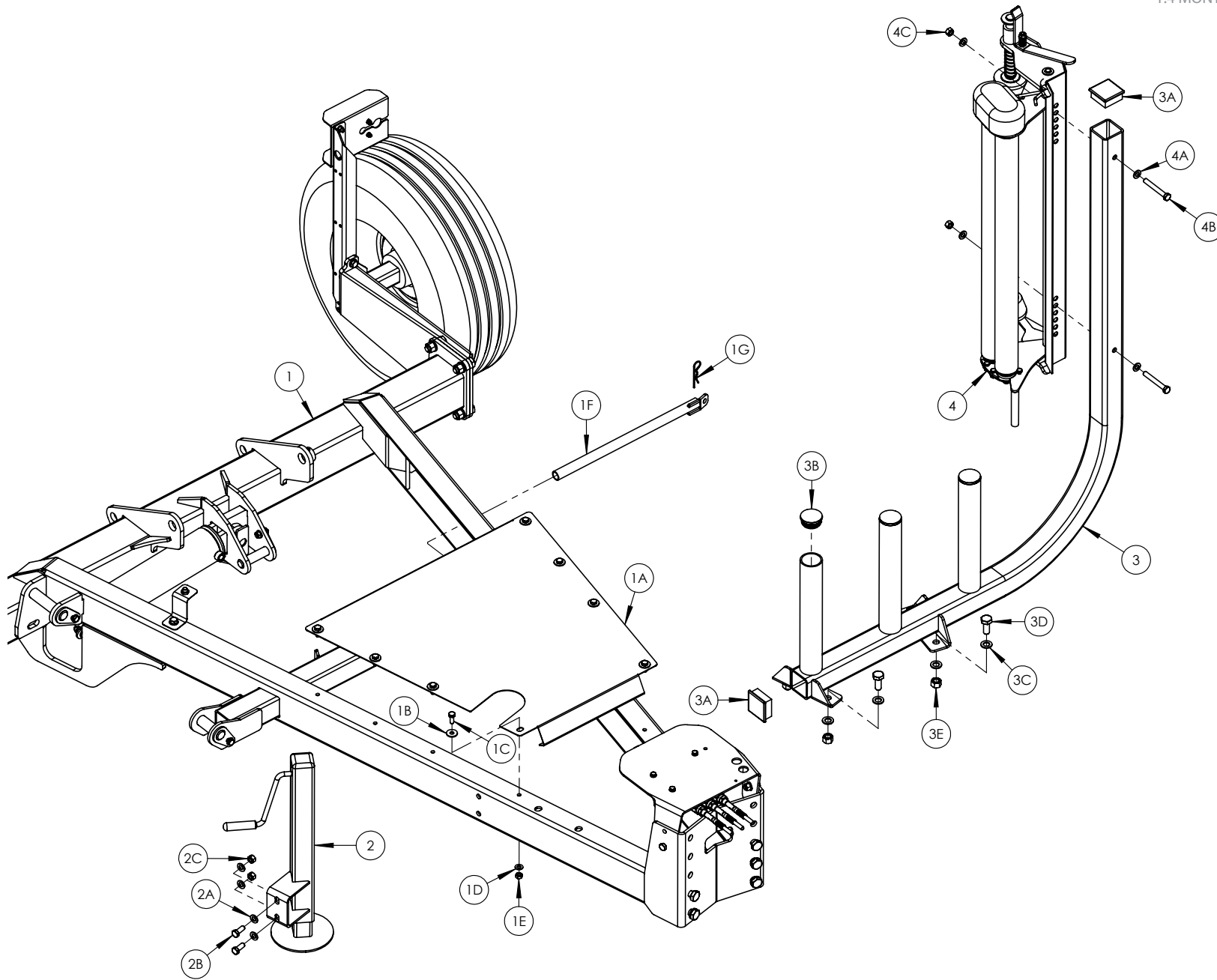

POS. NR.	TEILE NR.	STUCK	BENENNUNG	DESCRIPTION	DESIGNATION	TECHNISCHE ANGABEN
POS. NR.	PART NR.	QUANTITY				TECHNICAL DATA
POS. NO.	PIECE NO.	QUANTITEE				DONNEES TECHNIQUES
1	2001000	1	Fahrgestell	Chassis	Châssis	
1A	2001302	1	Fahrgestellverkleidung	Chassis Cover	Capot du châssis	
1B	Z11-02-101	8	Dichtring	Mud Washer	Rondelle de pare-boue	M10
1C	Z26-0611S	8	Innensechskantschraube	Hex Set	Vis de régl. Hex	M10 x 25mm
1D	Z10-02-10	8	Unterlegscheibe	Flat Washer	Rondelle plate	M10
1E	Z23-10	8	Feststellmutter	Locknut	Contre-écrou	M10
1F	2001255	1	Sicherheitsbügel	Safety Arm	Bras de sécurité	M12
1G	Z36-01	1	Haltebügel	R Clip	Clip « R »	3mm
2	2001250	1	Heberbaugruppe	Jack Assembly	Cric	
2A	Z10-02-12	4	Unterlegscheibe	Flat Washer	Rondelle plate	M12
2B	Z26-082S	2	Innensechskantschraube	Hex Set	Vis de régl. Hex	M12 x 30mm
2C	Z23-12	2	Feststellmutter	Locknut	Contre-écrou	M12
3	2005100	1	Vorstreckerbefestigung	Dispenser Mounting	Fixation du distributeur	
3A	Z32-086	2	Plastikkappe	Plastic Cap	Capuchon plastique	Int. 70 x 70
3B	Z32-081	3	Plastikkappe	Plastic Cap	Capuchon plastique	Inr. Ø2 3/8"
3C	Z10-02-16	8	Unterlegscheibe	Flat Washer	Rondelle plate	M16
3D	Z26-122S	4	Innensechskantschraube	Hex Set	Vis de régl. Hex	M16 x 40mm
3E	Z23-16	4	Feststellmutter	Locknut	Contre-écrou	M16
4	2005150	1	Vorstreckerbaugruppe	Dispenser Assembly	Ensemble Distributeur	
4A	Z10-02-12	4	Unterlegscheibe	Flat Washer	Rondelle plate	M12
4B	Z26-091B	2	Sechskantschraube	Hex Bolt	Boulon Hex	M12 x 90mm
4C	Z23-12	2	Feststellmutter	Locknut	Contre-écrou	M12

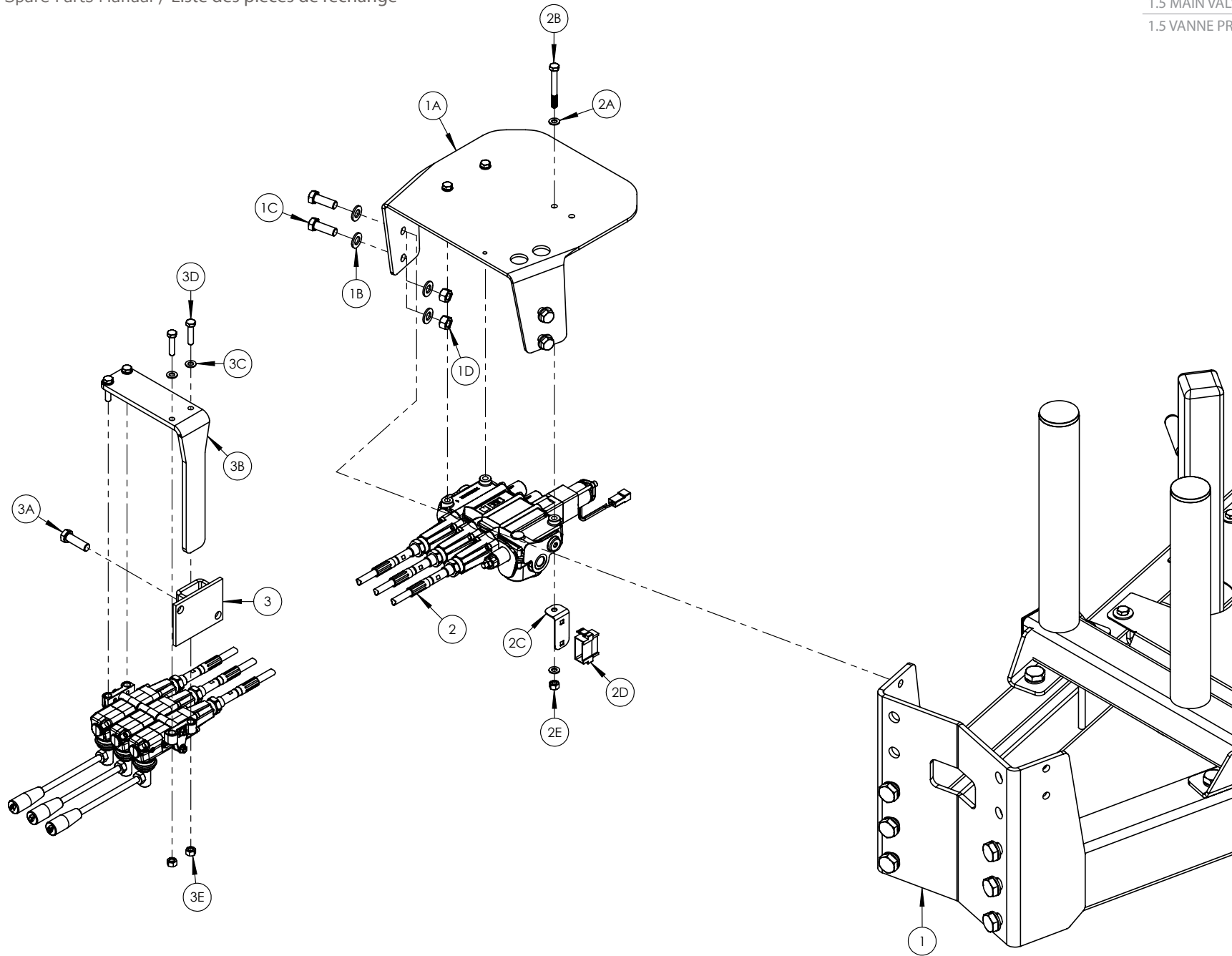

POS. NR.	TEILE NR.	STUCK	BENENNUNG	DESCRIPTION	DESIGNATION	TECHNISCHE ANGABEN
POS. NR.	PART NR.	QUANTITY				TECHNICAL DATA
POS. NO.	PIECE NO.	QUANTITEE				DONNEES TECHNIQUES
1	2001000	1	Fahrgestell	Chassis	Châssis	
1A	2001301	1	Ventilbefestigungsprofil	Valve Mounting Profile	Profilé de montage de vanne	
1B	Z10-02-12	8	Unterlegscheibe	Flat Washer	Rondelle plate	M12
1C	Z26-0835	4	Innensechskantschraube	Hex Set	Vis de régl. Hex	M12 x 35mm
1D	Z23-12	4	Feststellmutter	Locknut	Contre-écrou	M12
2	2008100	1	Steuerventil	Control Valve	Vanne de régulation	
2A	Z10-02-08	3	Unterlegscheibe	Flat Washer	Rondelle plate	M8
2B	Z26-049B	3	Sechskantschraube	Hex Bolt	Boulon Hex	M8 x 70mm
2C	2001311	1	Halterung	Bracket	Guide-support	
2D	Z785-565	1	Verbindungsstück	Connector	Connecteur	
2E	Z23-08	3	Feststellmutter	Locknut	Contre-écrou	M8
3	WD66-AML	1	Hebelhalterung	Lever Bracket	Support de levier	
3A	Z26-0845	1	Innensechskantschraube	Hex Set	Vis de régl. Hex	M12 x 40mm
3B	2001304	1	Hebelprofil	Lever Profile	Profilé de levier	
3C	Z10-02-08	4	Unterlegscheibe	Flat Washer	Rondelle plate	M8
3D	Z26-0425	4	Innensechskantschraube	Hex Set	Vis de régl. Hex	M8 x 35mm
3E	Z23-08	4	Feststellmutter	Locknut	Contre-écrou	M8



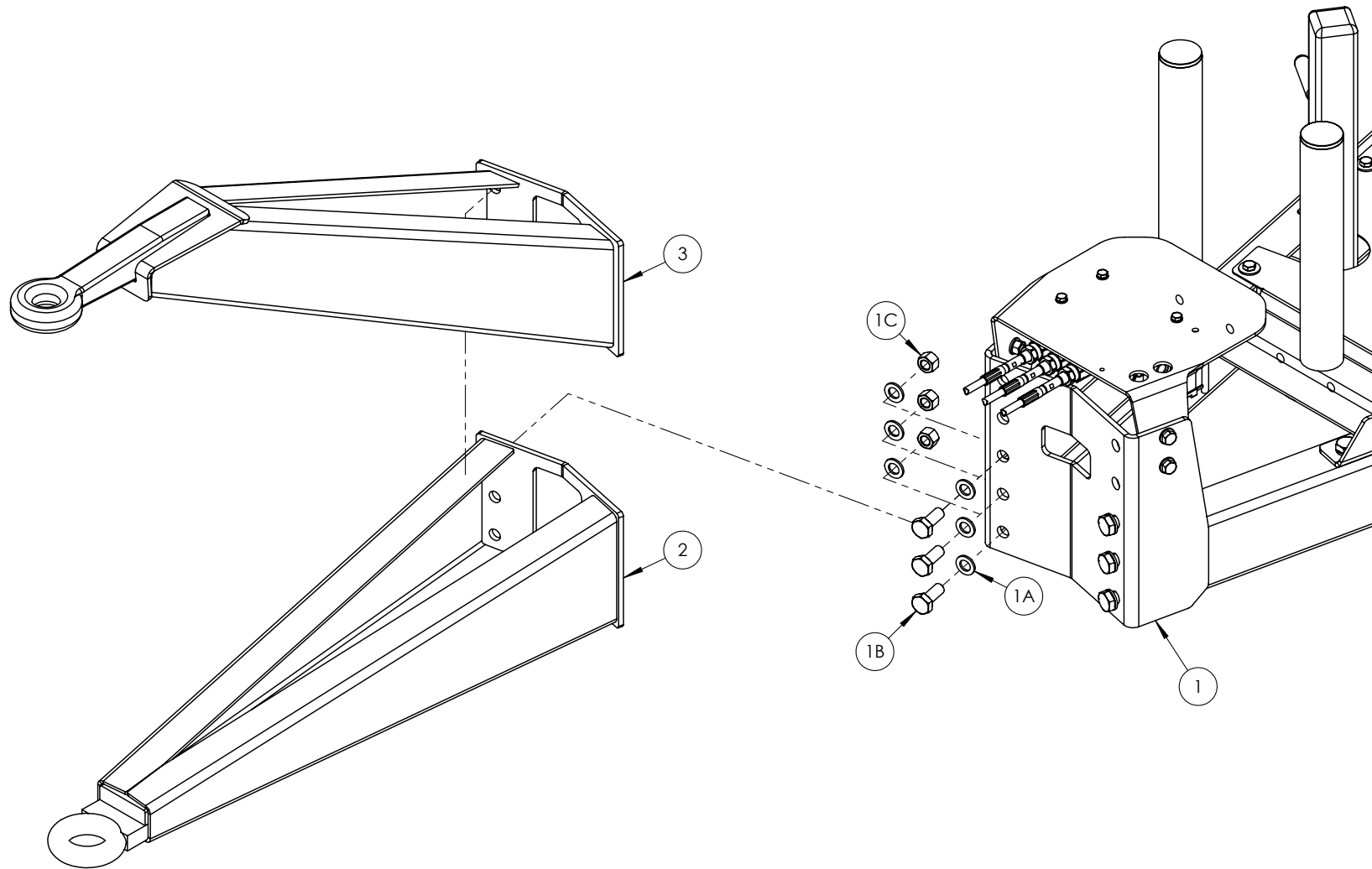

POS. NR.	TEILE NR.	STUCK	BENENNUNG	DESCRIPTION	DESIGNATION	TECHNISCHE ANGABEN
POS. NR.	PART NR.	QUANTITY				TECHNICAL DATA
POS. NO.	PIECE NO.	QUANTITEE				DONNEES TECHNIQUES
1	2001000	1	Fahrgestell	Chassis	Châssis	
1A	Z10-02-16	12	Unterlegscheibe	Flat Washer	Rondelle plate	M16
1B	Z26-122S	6	Innensechskantschraube	Hex Set	Vis de régl. Hex	M16 x 40mm
1C	Z23-16	6	Feststellmutter	Locknut	Contre-écrou	M16
2	2001100	1*	Standardanhängevorrichtung	Standard Hitch	Attelage standard	
3	2001110	1*	Hohe Anhängervorrichtung	High Hitch	Attelage haut	
			* Marktabhängig	* Market Dependant	* Fonction du marché	



Tanco Autowrap - E100

Ersatzteilliste / Spare Parts Manual / Liste des pièces de rechange

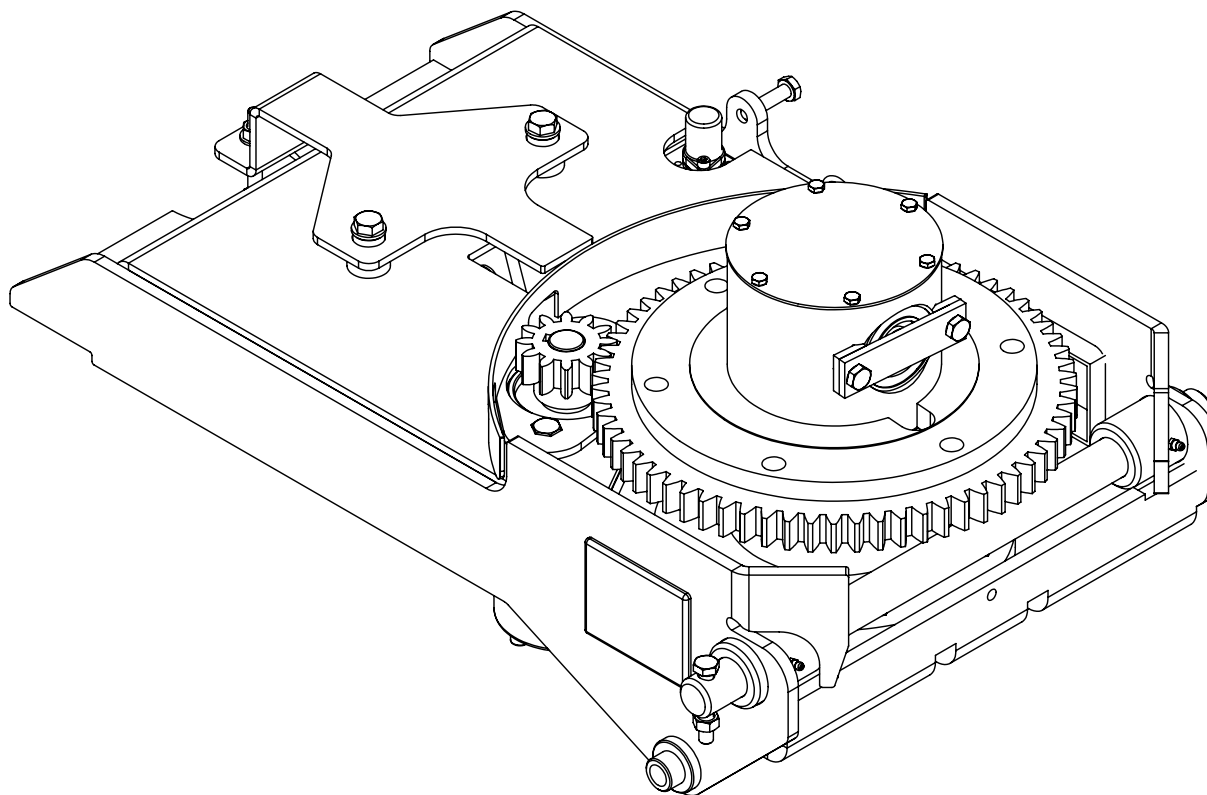

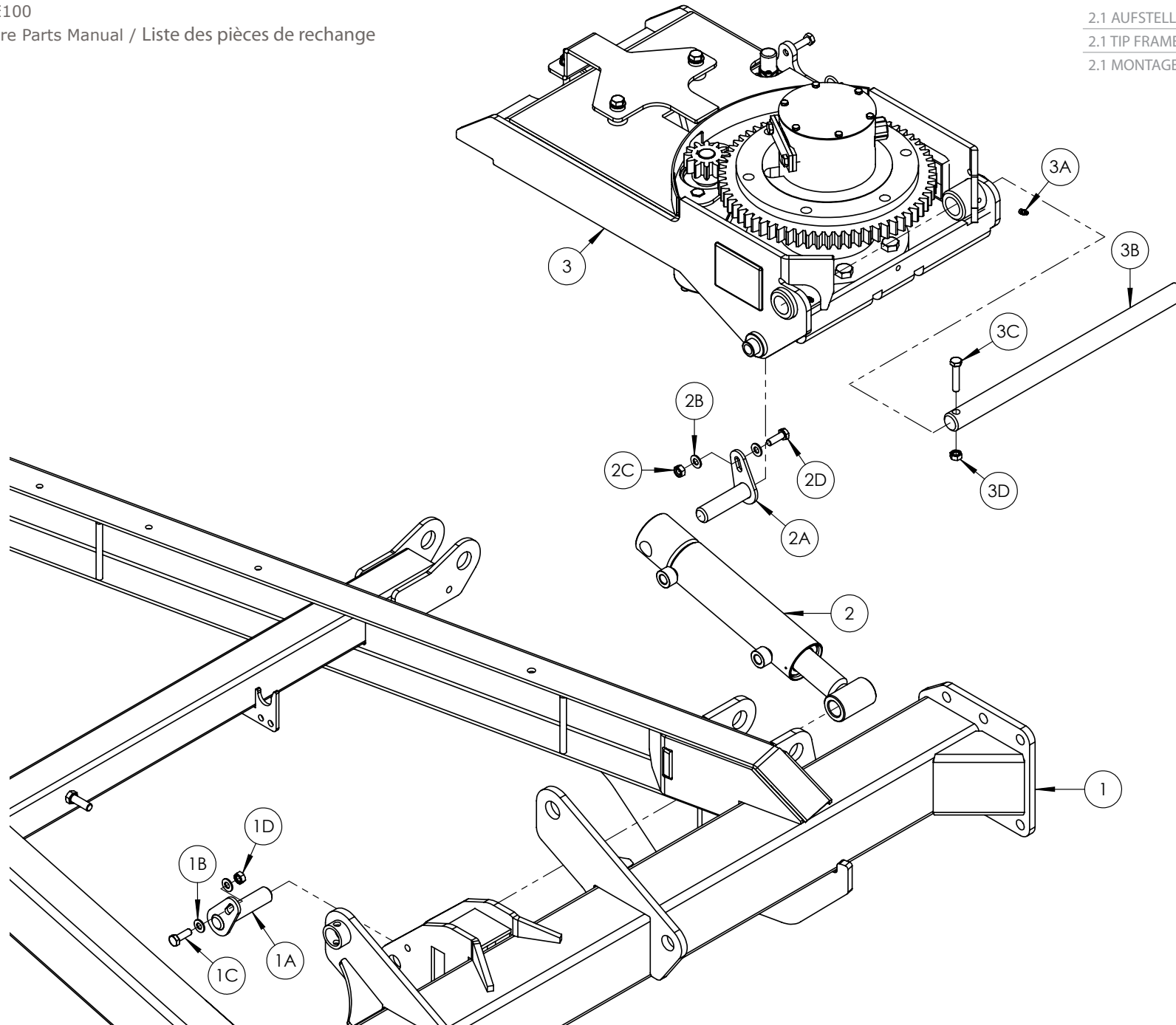

POS. NR.	TEILE NR.	STUCK	BENENNUNG	DESCRIPTION	DESIGNATION	TECHNISCHE ANGABEN
POS. NR.	PART NR.	QUANTITY				TECHNICAL DATA
POS. NO.	PIECE NO.	QUANTITEE				DONNEES TECHNIQUES
1	2001000	1	Fahrgestell	Chassis	Châssis	
1A	2001530	1	Zylinderstift	Cylinder Pin	Axe du vérin	
1B	Z10-02-10	2	Unterlegscheibe	Flat Washer	Rondelle plate	M10
1C	Z26-062S	1	Innensechskantschraube	Hex Set	Vis de régl. Hex	M10 x 30mm
1D	Z23-10	1	Feststellmutter	Locknut	Contre-écrou	M10 x 30mm
2	2008010	1	Aufstellzylinder	Tip Cylinder	Vérin de basculement	
2A	2001540	1	Zylinderstift	Cylinder Pin	Axe du vérin	
2B	Z10-02-10	2	Unterlegscheibe	Flat Washer	Rondelle plate	M10
2C	Z26-062S	1	Innensechskantschraube	Hex Set	Vis de régl. Hex	M10 x 30mm
2D	Z23-10	1	Feststellmutter	Locknut	Contre-écrou	M10 x 30mm
3	2002000	1	Aufstellrahmen	Tip Frame	Bâti de basculement	
3A	34060800	2	Schmiernippel	Grease Nipple	Raccord graisseur	M8
3B	2001550	1	Gelenkwelle	Pivot Shaft	Axe pivot	
3C	Z26-066S	1	Innensechskantschraube	Hex Set	Vis de régl. Hex	M10 x 50mm
3D	Z23-10	1	Feststellmutter	Locknut	Contre-écrou	M10

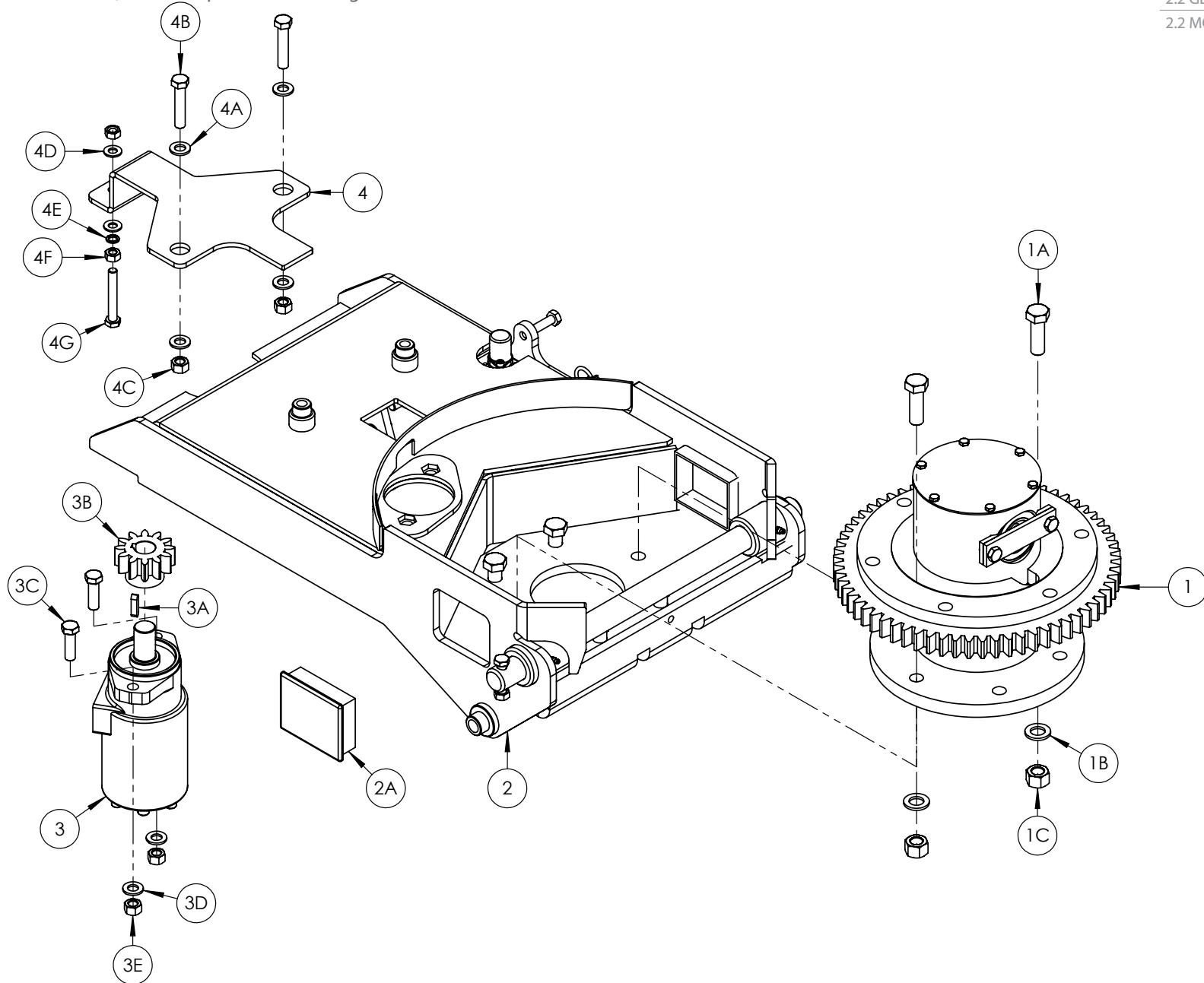

POS. NR. POS. NR. POS. NO.	TEILE NR. PART NR. PIECE NO.	STUCK QUANTITY QUANTITEE	BENENNUNG	DESCRIPTION	DESIGNATION	TECHNISCHE ANGABEN TECHNICAL DATA DONNEES TECHNIQUES
1	2003500	1	Getriebeeinheit	Gear Assembly	Engrenage	
1A	Z26-125B	6	Sechskantschraube	Hex Bolt	Boulon Hex	M16 x 50mm
1B	Z10-02-16	6	Unterlegscheibe	Flat Washer	Rondelle plate	M16
1C	Z23-16	6	Feststellmutter	Locknut	Contre-écrou	M16
2	2002000	1	Aufstellrahmen	Tip Frame	Bâti de basculement	
2A	Z32-114	2	Plastikeinsatz	Plastic Insert	Insert plastique	100 x 80mm
3	2008150	1	Motor	Motor	Moteur	
3A	34270111	1	Passfeder	Key Steel	Clavette acier	8 x 7 x 30mm
3B	2003525	1	Motorgetriebe	Motor Gear	Engrenage moteur	12T
3C	Z26-084	2	Sechskantschraube	Hex Bolt	Boulon Hex	M12 x 40mm
3D	Z10-02-12	4	Unterlegscheibe	Flat Washer	Rondelle plate	M12
3E	Z23-12	2	Feststellmutter	Locknut	Contre-écrou	M12
4	2001303	1	Auslöseprofil	Trip Profile	Profilé de déclenchement	
4A	Z10-02-12	4	Unterlegscheibe	Flat Washer	Rondelle plate	M12
4B	Z26-0885	2	Innensechskantschraube	Hex Set	Vis de régl. Hex	M12 x 60mm
4C	Z10-02-10	2	Unterlegscheibe	Flat Washer	Rondelle plate	M10
4D	Z12-02-10	1	Federscheibe	Sping Washer	Rondelle à ressort	M10
4E	Z18-10	1	Sechskantmutter, glatt	Plain Hex Nut	Écrou plein Hex	M10
4F	Z26-068B	1	Sechskantschraube	Hex Bolt	Boulon Hex	M10 x 70mm



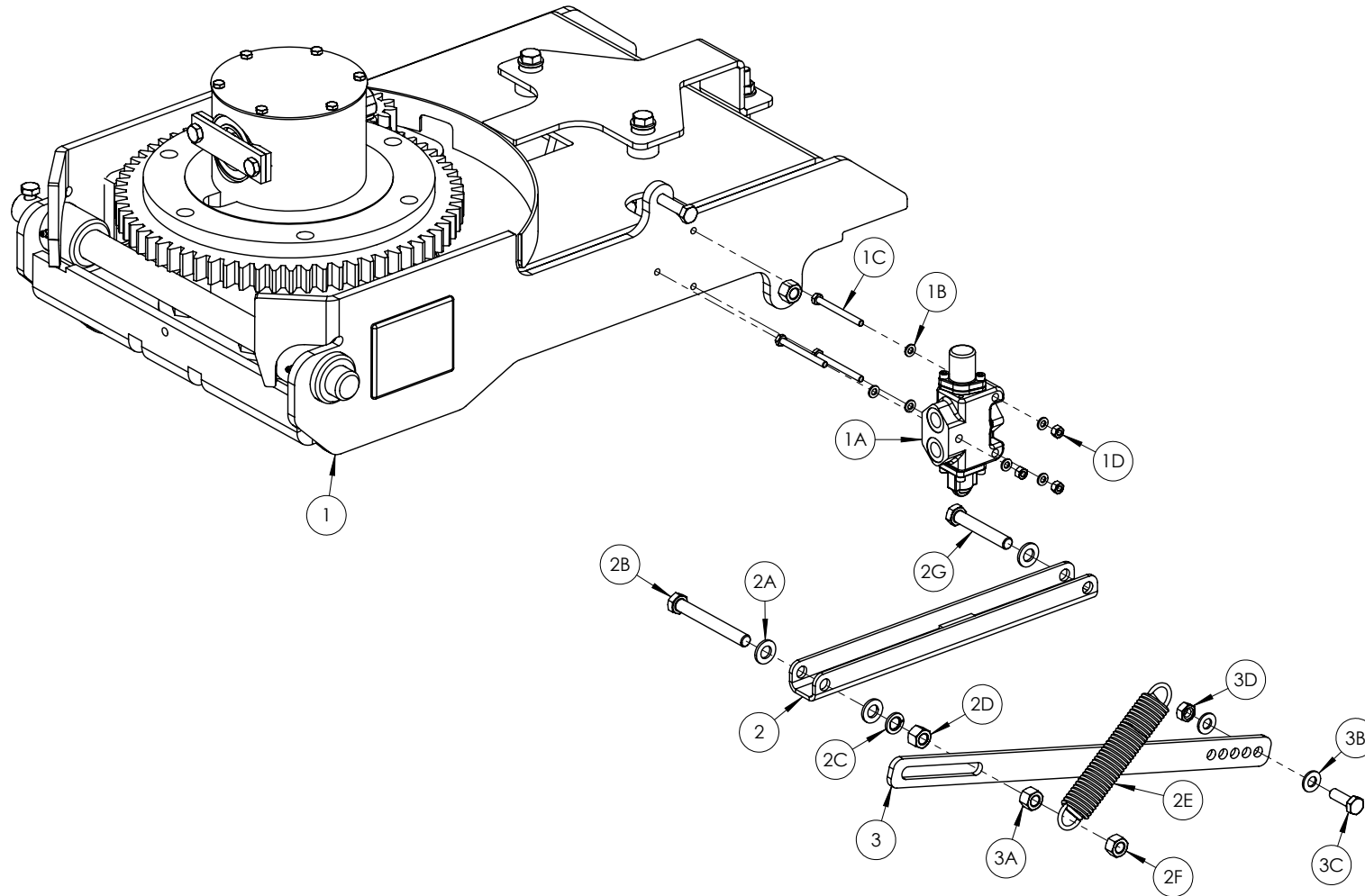

POS. NR.	TEILE NR.	STUCK	BENENNUNG	DESCRIPTION	DESIGNATION	TECHNISCHE ANGABEN
POS. NR.	PART NR.	QUANTITY				TECHNICAL DATA
POS. NO.	PIECE NO.	QUANTITEE				DONNEES TECHNIQUES
1	2002000	1	Aufstellrahmen	Tip Frame	Bâti de basculement	
1A	1103109	1	Betätigungsventil	Actuator Valve	Vanne de commande	
1B	Z10-02-06	6	Unterlegscheibe	Flat Washer	Rondelle plate	M6
1C	Z26-029B	3	Sechskantschraube	Hex Bolt	Boulon Hex	M6 x 65mm
1D	Z23-06	3	Feststellmutter	Locknut	Contre-écrou	M6
2	2001305	1	Betätigungsbügel	Actuator Bracket	Support d'actionneur	
2A	Z10-02-12	4	Unterlegscheibe	Flat Washer	Rondelle plate	M12
2B	Z26-092S	1	Sechskantschraube	Hex Bolt	Boulon Hex	M12 x 100mm
2C	Z12-02-12	1	Federscheibe	Spring Washer	Rondelle à ressort	M12
2D	Z18-12	1	Sechskantmutter, glatt	Plain Hex Nut	Écrou plein Hex	
2E	Z07-09	1	Zugfeder	Extension Spring	Ressort d'extension	
2F	Z23-12	1	Feststellmutter	Locknut	Contre-écrou	M12
2G	Z26-090B	1	Sechskantschraube	Hex Bolt	Boulon Hex	M12 x 75mm
3	20013010	1	Betätigungsprofil	Actuator Profile	Profilé pour actionneur	
3A	Z18-12	1	Sechskantmutter, glatt	Plain Hex Nut	Écrou plein Hex	M12
3B	Z10-02-10	2	Unterlegscheibe	Flat Washer	Rondelle plate	M10
3C	Z26-062S	1	Innensechskantschraube	Hex Set	Vis de régl. Hex	M10 x 30mm
3D	Z23-10	1	Feststellmutter	Locknut	Contre-écrou	M10



Tanco Autowrap - E100

Ersatzteilliste / Spare Parts Manual / Liste des pièces de rechange

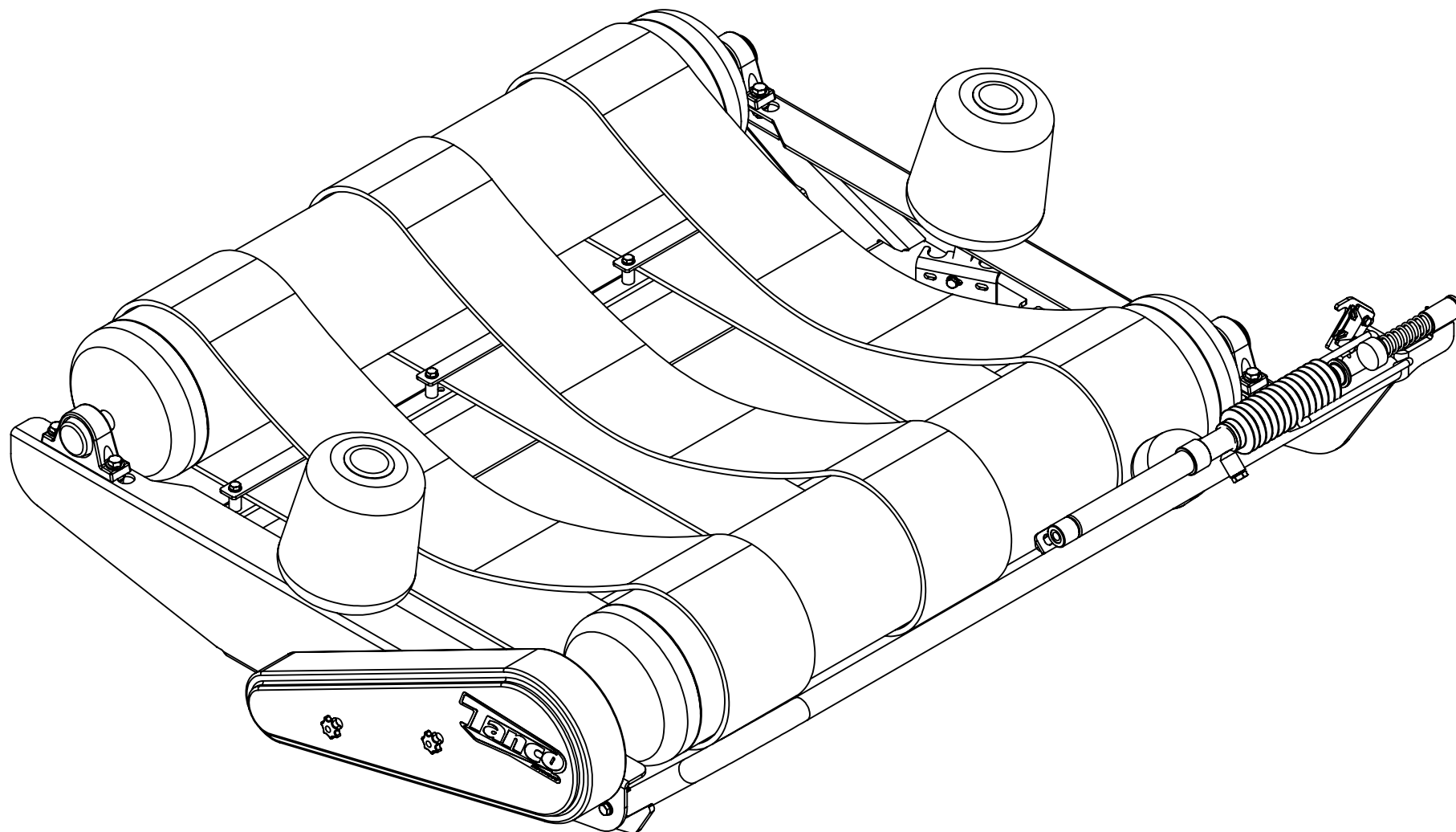

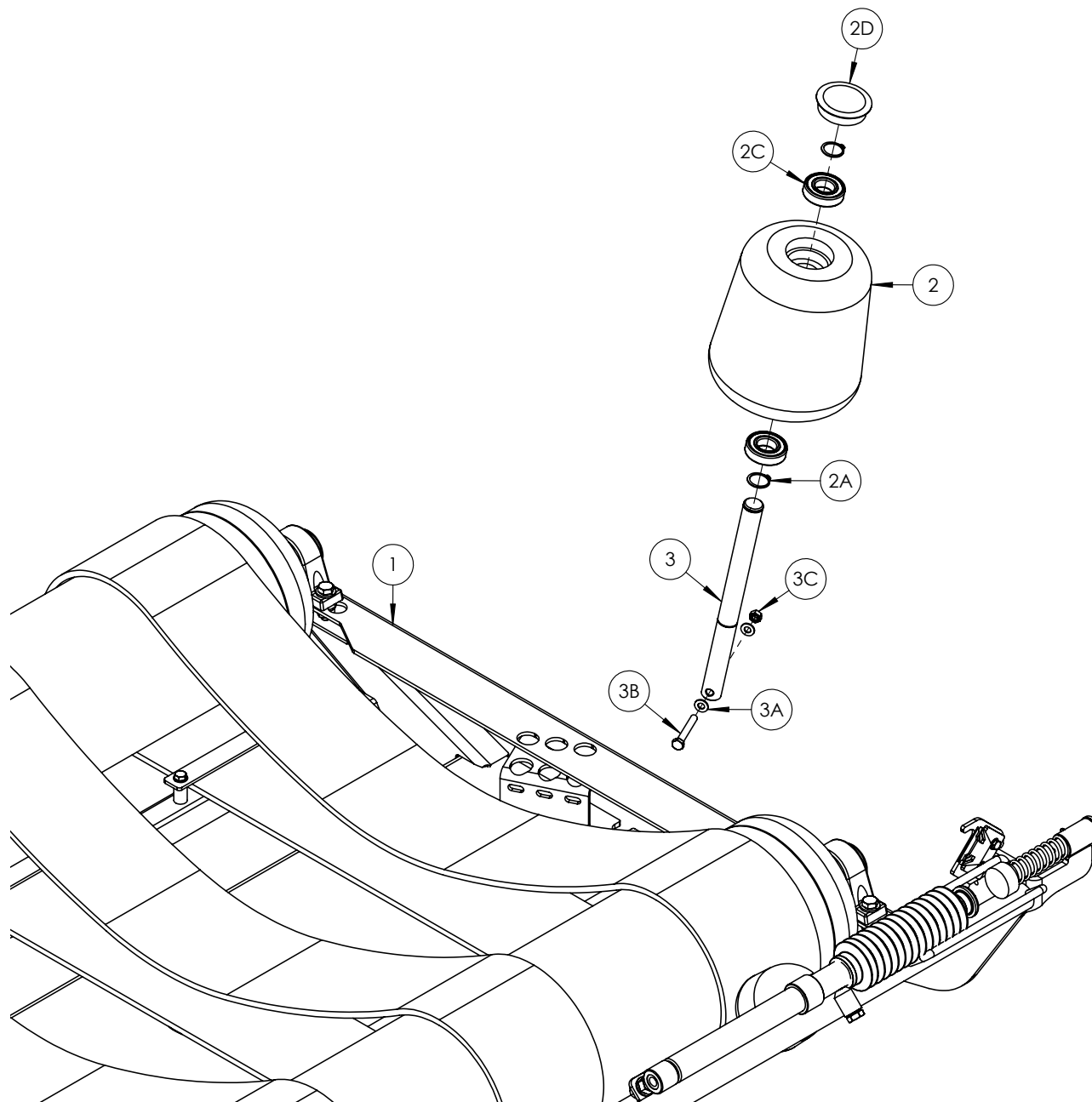

POS. NR.	TEILE NR.	STUCK	BENENNUNG	DESCRIPTION	DESIGNATION	TECHNISCHE ANGABEN
POS. NR.	PART NR.	QUANTITY				TECHNICAL DATA
POS. NO.	PIECE NO.	QUANTITEE				DONNEES TECHNIQUES
1	2003000	1	Drehtisch	Turntable	Table pivotante	
2	34130258	1	Rollenwelle	Roller Shaft	Arbre du rouleau	
2A	Z10-02-10	2	Unterlegscheibe	Flat Washer	Rondelle plate	M10
2B	Z26-0685	1	Innensechskantschraube	Hex Set	Vis de régl. Hex	M10 x 70mm
2C	Z23-10	1	Feststellmutter	Locknut	Contre-écrou	M10
3	34340141	1	Plastikrolle	Plastic Roller	Rouleau plastique	
3A	34240708	2	Seegerring	Circlip	Circlip	A30
3B	34320508	2	Lager	Bearing	Palier	6206 2RS
3C	34450447	1	Plastikkappe	Plastic Cap	Capuchon plastique	



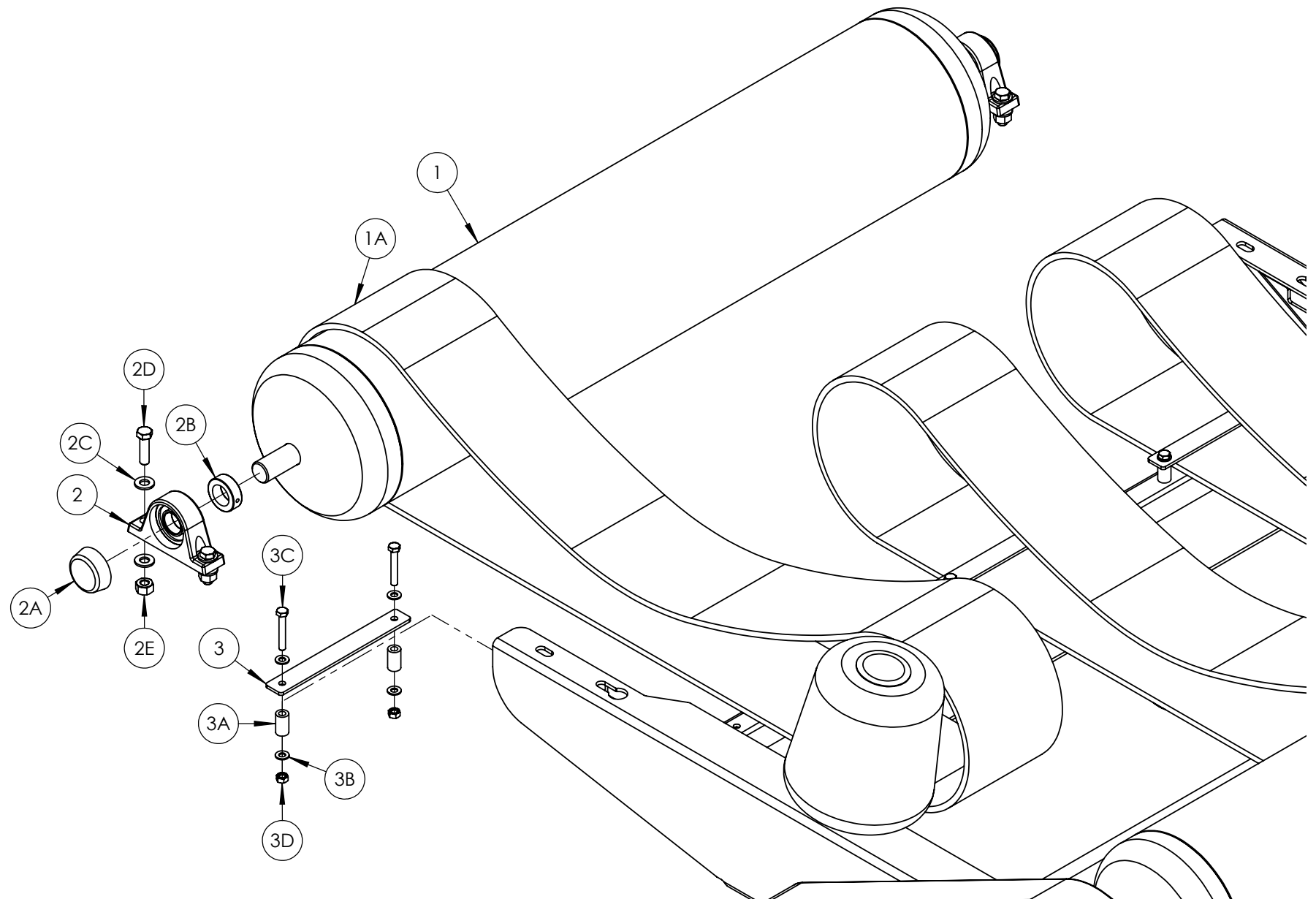

POS. NR.	TEILE NR.	STUCK	BENENNUNG	DESCRIPTION	DESIGNATION	TECHNISCHE ANGABEN
POS. NR.	PART NR.	QUANTITY				TECHNICAL DATA
POS. NO.	PIECE NO.	QUANTITEE				DONNEES TECHNIQUES
1	2003110	1	Spannrolle	Idler Roller	Rouleau-guide	
1A	Z05-02-ILS	3	Riemen	Belt	Courroie	
2	Z06-485-35	2	Lager	Bearing	Palier	35mm
2A	Z06-485-CAP	2	Lagerdeckel	Bearing Cap	Couvercle de palier	
2B	Z06-485-35-LC	2	Spannring	Locking Collar	Bague de blocage	35mm
2C	Z10-02-14	8	Unterlegscheibe	Flat Washer	Rondelle plate	M14
2D	Z26-104B	4	Innensechskantschraube	Hex Set	Vis de régl. Hex	M14 x 50mm
2E	Z23-14	4	Feststellmutter	Locknut	Contre-écrou	M14
3	2003105	1	Riemenführung	Belt Guide	Guide-courroie	
3A	2003106	2	Distanzstück	Spacer	Entretoise	
3B	Z10-02-10	4	Unterlegscheibe	Flat Washer	Rondelle plate	M10
3C	Z26-0671B	2	Innensechskantschraube	Hex Set	Vis de régl. Hex	M10 x 65mm
3D	Z23-10	2	Feststellmutter	Locknut	Contre-écrou	M10

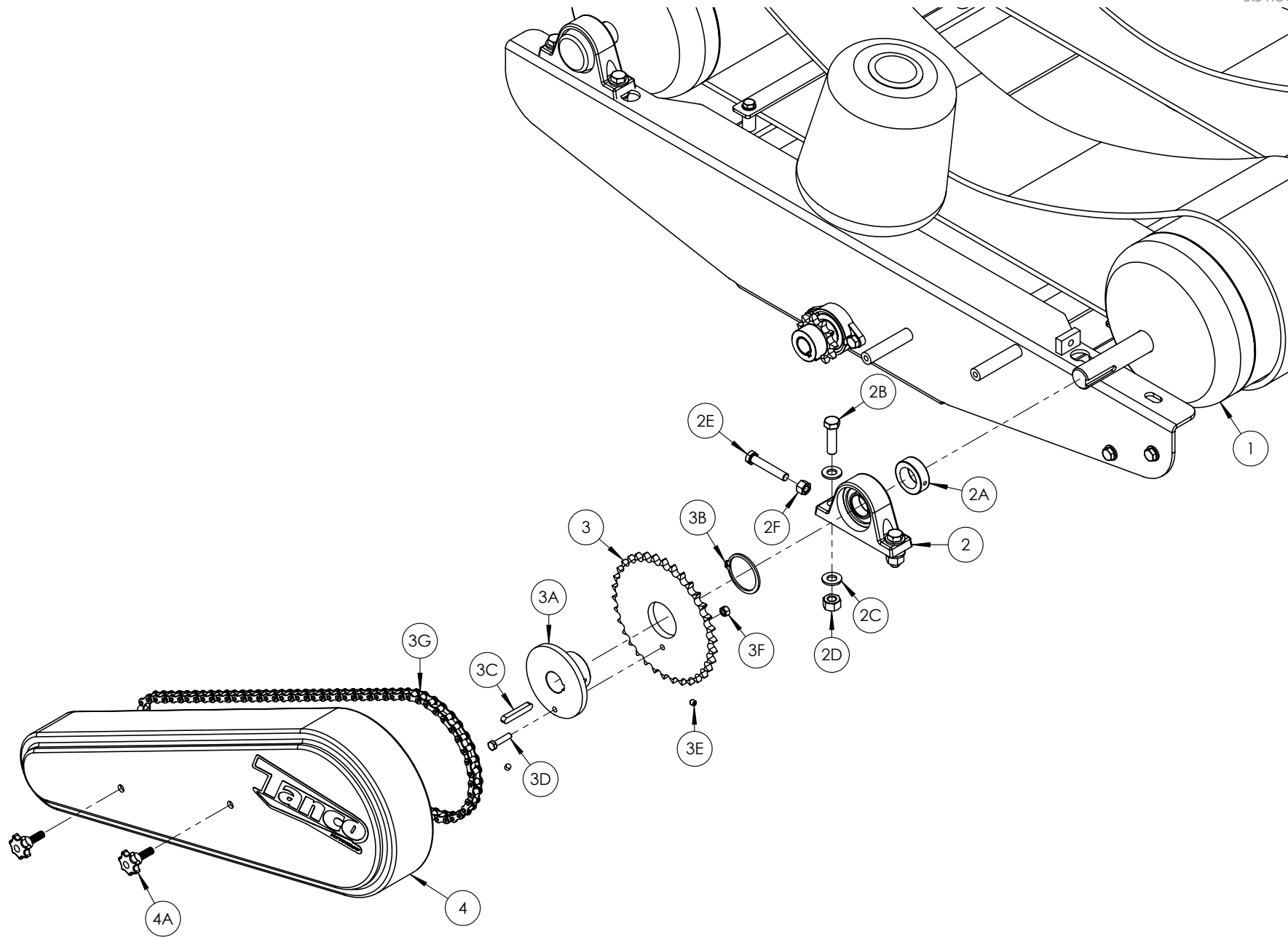

POS. NR.	TEILE NR.	STUCK	BENENNUNG	DESCRIPTION	DESIGNATION	TECHNISCHE ANGABEN
POS. NR.	PART NR.	QUANTITY				TECHNICAL DATA
POS. NO.	PIECE NO.	QUANTITEE				DONNEES TECHNIQUES
1	2003100	1	Antriebsrolle	Drive Roller	Rouleau moteur	
2	Z06-485-35	2	Lager	Bearing	Palier	35mm
2A	Z06-485-35-LC	2	Spannring	Locking Collar	Bague de blocage	35mm
2B	Z26-104B	4	Innensechskantschraube	Hex Set	Vis de régl. Hex	M14 x 50mm
2C	Z10-02-14	8	Unterlegscheibe	Flat Washer	Rondelle plate	M14
2D	Z23-14	4	14 mm Feststellmutter	14mm Locknut	Contre-écrou 14mm	M14
2E	Z26-089S	1	Innensechskantschraube	Hex Set	Vis de régl. Hex	M12 x 70mm
2F	Z18-10	1	Sechskantmutter, glatt	Plain Hex Nut	Écrou plein Hex	M10
3	2003212	1	Kettenrad	Sprocket	Pignon	28T
3A	2003211	1	Kettenradnabe	Sprocket Hub	Moyeu de pignon	
3B	2003213	1	Seegerring	Cir Clip	Circlip	57mm Ext.
3C	2003217	1	Passfeder	Key Steel	Clavette acier	10 x 8 x 55mm
3D	Z26-042B	1	Sechskantschraube	Hex Bolt	Boulon Hex	M8 x 35mm
3E	Z28-008	2	Gewindestift	Grub Screw	Vis sans tête	M8
3F	Z23-08	1	Feststellmutter	Locknut	Contre-écrou	M8
3G	Z09-AW-58	1	Antriebskette	Drive Chain	Chaîne de transmission	3/4" (84 Links)
4	2003220	1	Kettendeckel	Chain Cover	Protection de la chaîne	
4A	Z49-95	2	Handbefestigung	Hand Fastener	Vis manuelle	M10 x 30

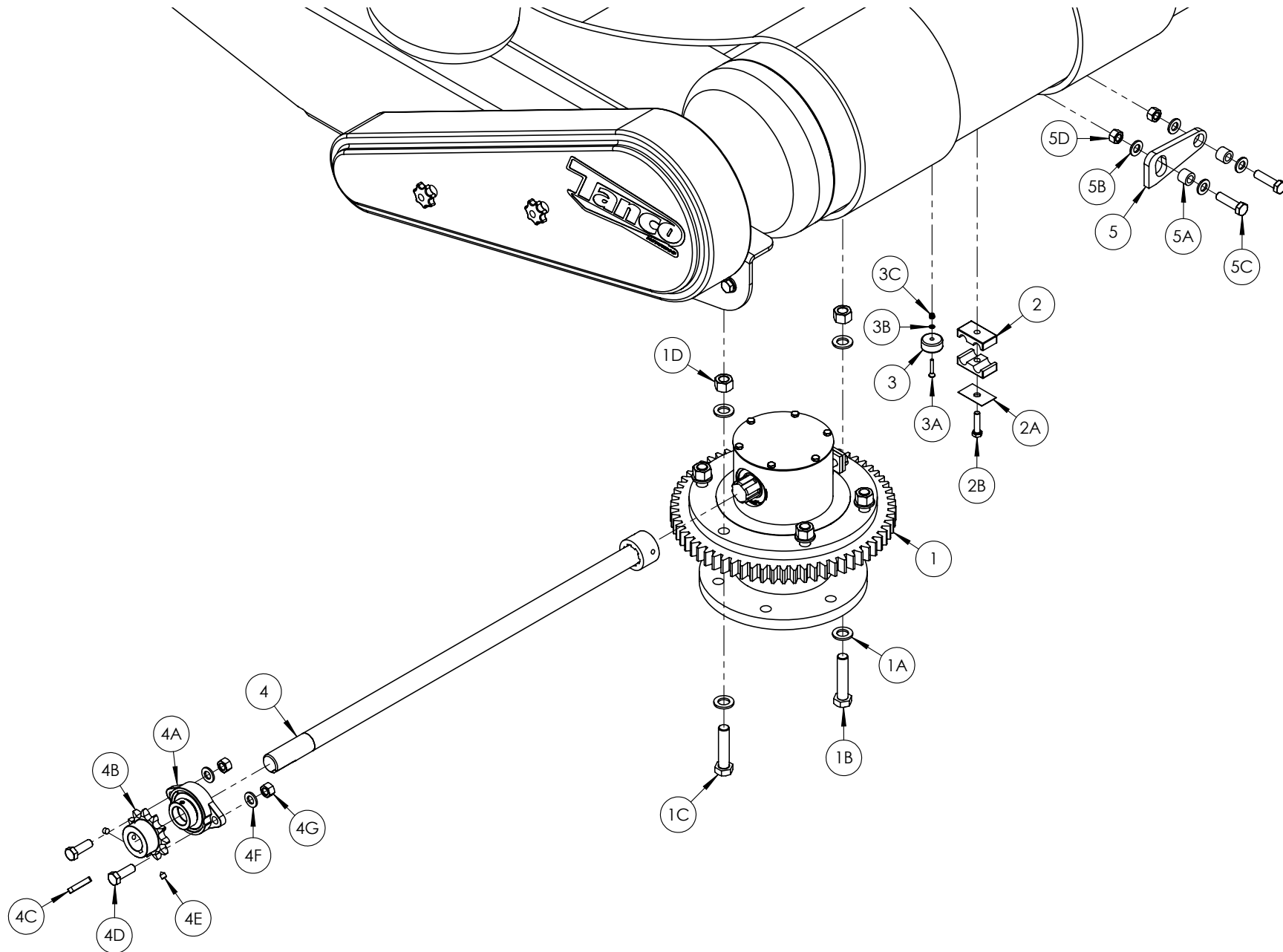

POS. NR.	TEILE NR.	STUCK	BENENNUNG	DESCRIPTION	DESIGNATION	TECHNISCHE ANGABEN
POS. NR.	PART NR.	QUANTITY				TECHNICAL DATA
POS. NO.	PIECE NO.	QUANTITEE				DONNEES TECHNIQUES
1	2003500	1	Getriebeeinheit	Gear Assembly	Engrenage	
1A	Z10-02-16	12	Unterlegscheibe	Flat Washer	Rondelle plate	M16
1B	Z26-129B	5	Innensechskantschraube	Hex Set	Vis de régl. Hex.	M16 x 75mm
1B	Z26-128S	1	Innensechskantschraube	Hex Set	Vis de régl. Hex.	M16 x 70mm
1D	Z23-16	6	Feststellmutter	Locknut	Contre-écrou	M16
2	Z01-24-26	1	Rohrschelle (Set)	Pipe Clamp (Set)	Collier de serrage (kit)	
2A	Z01-24-28	1	Rohrschellenplatte	Pipe Clamp Plate	Plaque de collier de serrage	
2B	Z26-042B	1	Innensechskantschraube	Hex Set	Vis de régl. Hex	M8 x 35mm
3	D60430	1	Sensormagnet	Sensor Magnet	Aimant de capteur	
3A	Z13-5-04X30	1	C.S. Schraube	C.S. Bolt	Boulon C.S.	M4 x 30mm
3B	Z10-02-04	1	Unterlegscheibe	Flat Washer	Rondelle plate	M4
3C	Z23-04	1	Feststellmutter	Locknut	Contre-écrou	M4
4	2003200	1	Antriebswelle	Drive Shaft	Arbre moteur	
4A	Z06-051	1	Lager	Bearing	Palier	SALF 206
4B	2003210	1	Antriebskettenrad	Drive Sprocket	Pignon d'entraînement	
4C	2003216	1	Passfeder	Key Steel	Clavette acier	8 x 7 x 44mm
4D	Z26-083S	2	Innensechskantschraube	Hex Set	Vis de régl. Hex	M12 x 35mm
4E	Z28-008	2	Gewindestift	Grub Screw	Vis sans tête	M8
4F	Z10-02-12	2	Unterlegscheibe	Flat Washer	Rondelle plate	M12
4G	Z23-12	2	Feststellmutter	Locknut	Contre-écrou	M12
5	2001306	1	Anschlagprofil	Stop Profile	Profilé de butée	
5A	2001307	2	Distanzstück	Spacer	Entretoise	
5B	Z10-02-12	4	Unterlegscheibe	Flat Washer	Rondelle plate	M12
5C	Z26-085S	2	Innensechskantschraube	Hex Set	Vis de régl. Hex	M12 x 45mm
5D	Z23-12	2	Feststellmutter	Locknut	Contre-écrou	M12

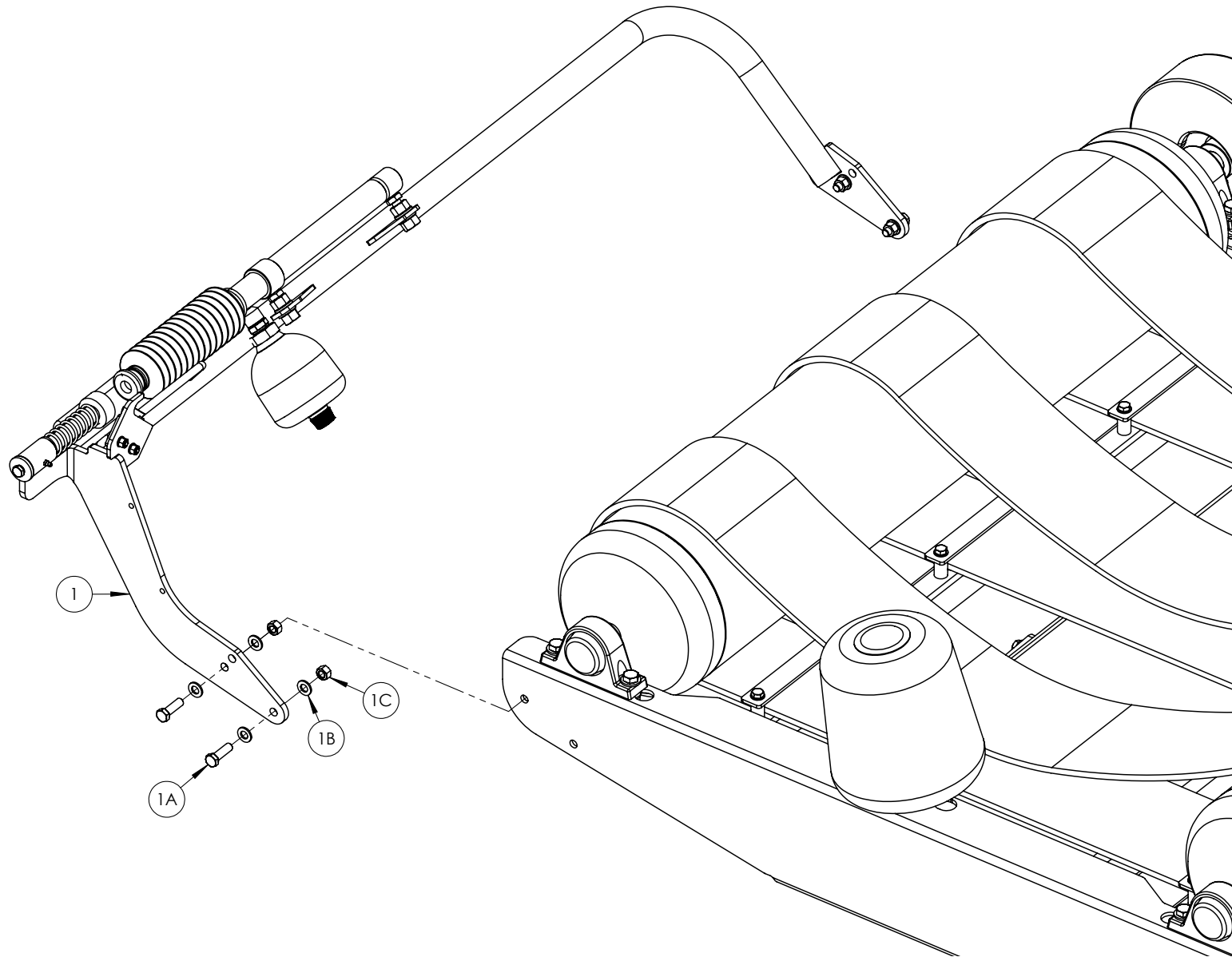

POS. NR.	TEILE NR.	STUCK	BENENNUNG	DESCRIPTION	DESIGNATION	TECHNISCHE ANGABEN
POS. NR.	PART NR.	QUANTITY				TECHNICAL DATA
POS. NO.	PIECE NO.	QUANTITEE				DONNEES TECHNIQUES
1	2003050	1	Schneid- & Binderahmen	Cut & Tie Frame	Bâti de coupe et d'attache	
1A	Z26-0845	4	Innensechskantschraube	Hex Set	Vis de régl. Hex	M12 x 40mm
1B	Z10-02-12	8	Unterlegscheibe	Flat Washer	Rondelle plate	M12
1C	Z23-12	4	Feststellmutter	Locknut	Contre-écrou	M12



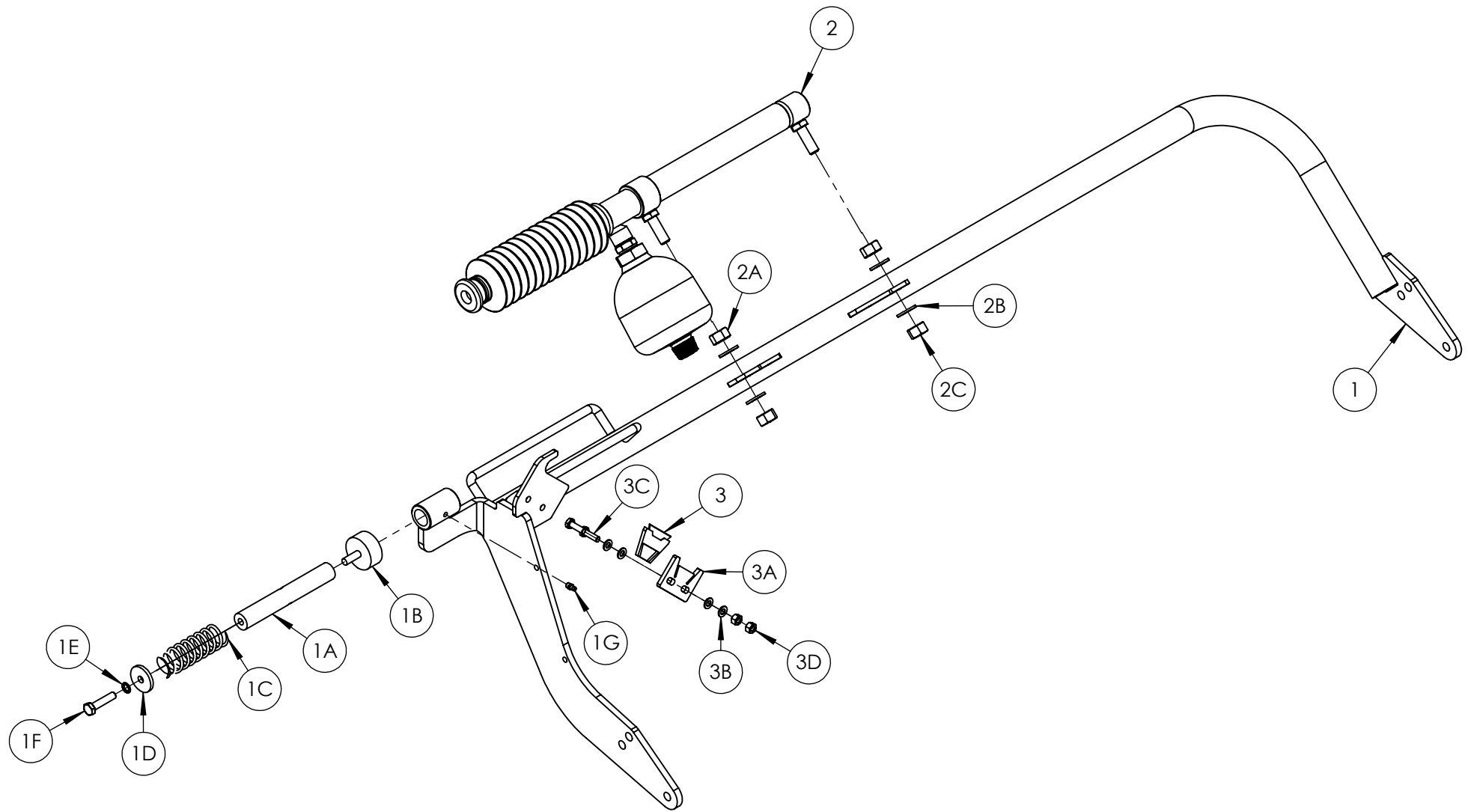

POS. NR.	TEILE NR.	STUCK	BENENNUNG	DESCRIPTION	DESIGNATION	TECHNISCHE ANGABEN
POS. NR.	PART NR.	QUANTITY				TECHNICAL DATA
POS. NO.	PIECE NO.	QUANTITEE				DONNEES TECHNIQUES
1	2003050	1	Schneid- & Binderahmen	Cut & Tie Frame	Bâti de coupe et d'attache	
1A	WD605H-13	1	Raststift	Plunger Pin	Goupille	
1B	Z40-28	1	Gummipuffer	Rubber Buffer	Tampon caoutchouc	Ø50 x 22mm
1C	Z07-49	1	Druckfeder	Compression Spring	Ressort à compression	
1D	WD623-071	1	Ring	Collar	Collier	
1E	Z12-02-10	1	Federscheibe	Spring Washer	Rondelle à ressort	M10
1F	Z26-0655	1	Innensechskantschraube	Hex Set	Vis de régl. Hex	M10 x 45mm
1G	34060800	1	Schmiernippel	Grease Nipple	Raccord graisseur	
2	2008030	1	Schneid- & Bindezylinder	Cut & Tie Cylinder	Vérin de coupe et d'attache	
2A	Z18-14	2	Sechskantmutter, glatt	Plain Hex Nut	Écrou plein Hex	M14
2B	Z10-02-14	4	Unterlegscheibe	Flat Washer	Rondelle plate	M14
2C	Z23-14	2	Feststellmutter	Locknut	Contre-écrou	M14
3	1004007	1	Klingenbaugruppe	Blade Assembly	Ensemble de lame	
3A	1004006	1	Klingenmontageprofil	Blade Mounting Profile	Profilé de fixation de lame	
3B	Z10-02-08	4	Unterlegscheibe	Flat Washer	Rondelle plate	M8
3C	Z26-0405	2	Innensechskantschraube	Hex Set	Vis de régl. Hex	M8 x 25mm
3D	Z23-08	2	Feststellmutter	Locknut	Contre-écrou	M8



Tanco Autowrap - E100

Ersatzteilliste / Spare Parts Manual / Liste des pièces de rechange

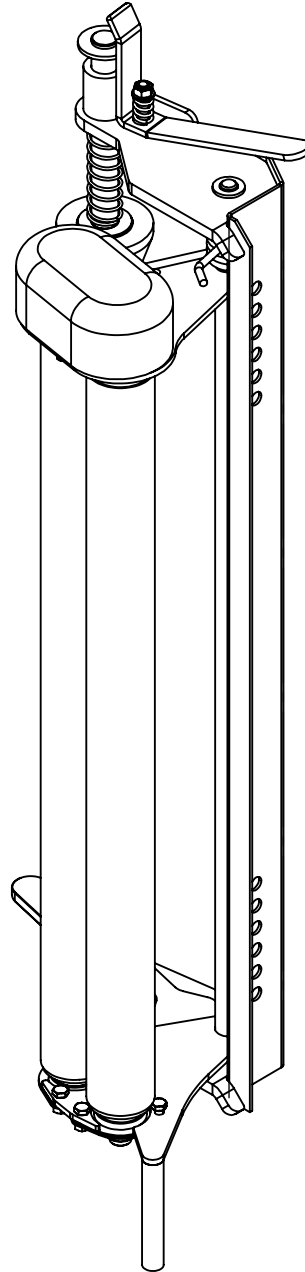

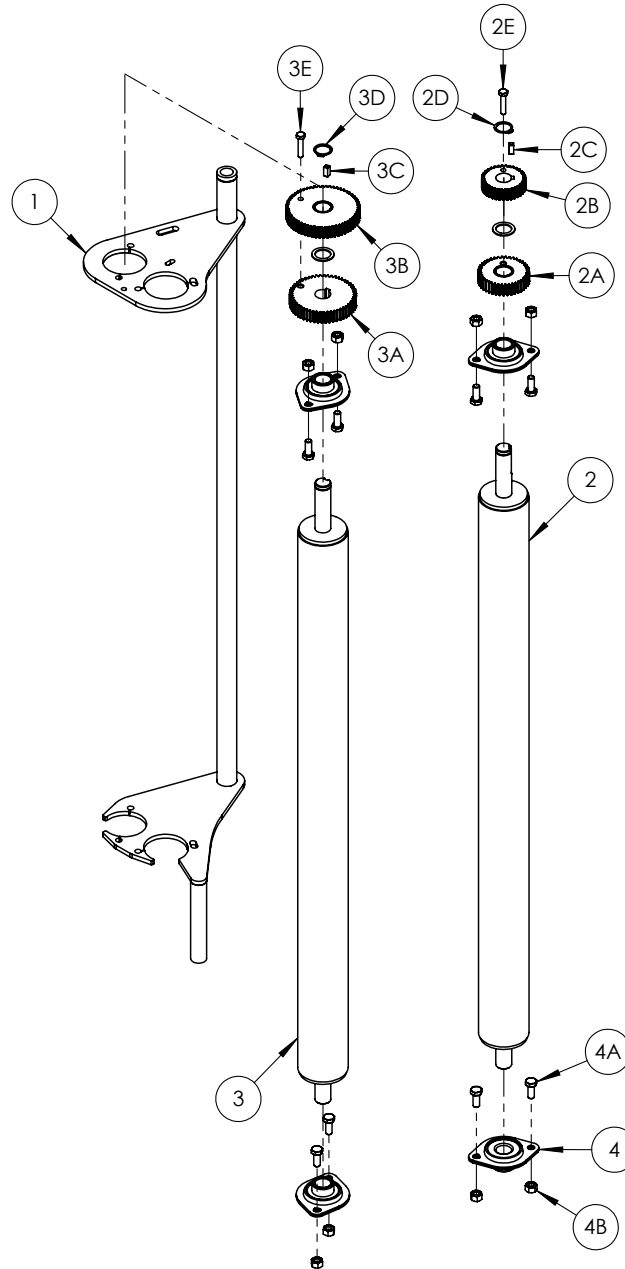

POS. NR.	TEILE NR.	STUCK	BENENNUNG	DESCRIPTION	DESIGNATION	TECHNISCHE ANGABEN
POS. NR.	PART NR.	QUANTITY				TECHNICAL DATA
POS. NO.	PIECE NO.	QUANTITEE				DONNEES TECHNIQUES
1	1205110	1	TW-Rollenanbaurahmen	TW Roller Mounting Frame	Cadre de fixation des rouleaux TW	
2	1305120	1	Walze, innen	Inner Roller	Rouleau intérieur	
2A	1305104	1	Zahnrad	Gear	Engrenage	37 T
2B	1305102	1	Zahnrad	Gear	Engrenage	35 T
2C	1305123	1	Passfeder	Key Steel	Clavette acier	6 x 6 x 15mm
2D	Z28-520	1	Seegerring	Cir Clip	Circlip	A20
2E	Z26-022S	1	Innensechskantschraube	Hex Set	Vis de régl. Hex	M6 x 30mm
3	1305121	1	Außenwalze	Outer Roller	Rouleau extérieur	
3A	1305101	1	Zahnrad	Gear	Engrenage	60 T
3B	1305103	1	Zahnrad	Gear	Engrenage	58 T
3C	1305123	1	Passfeder	Key Steel	Clavette acier	6 x 6 x 15mm
3D	Z28-520	1	Seegerring	Cir Clip	Circlip	A20
3E	Z26-022S	1	Innensechskantschraube	Hex Set	Vis de régl. Hex	M6 x 30mm
4	1305122	4	Lager	Bearing	Palier	SLFL 20A
4A	Z26-039S	8	Innensechskantschraube	Hex Set	Vis de régl. Hex	M8 x 20mm
4B	Z23-08	8	Feststellmutter	Locknut	Contre-écrou	M8



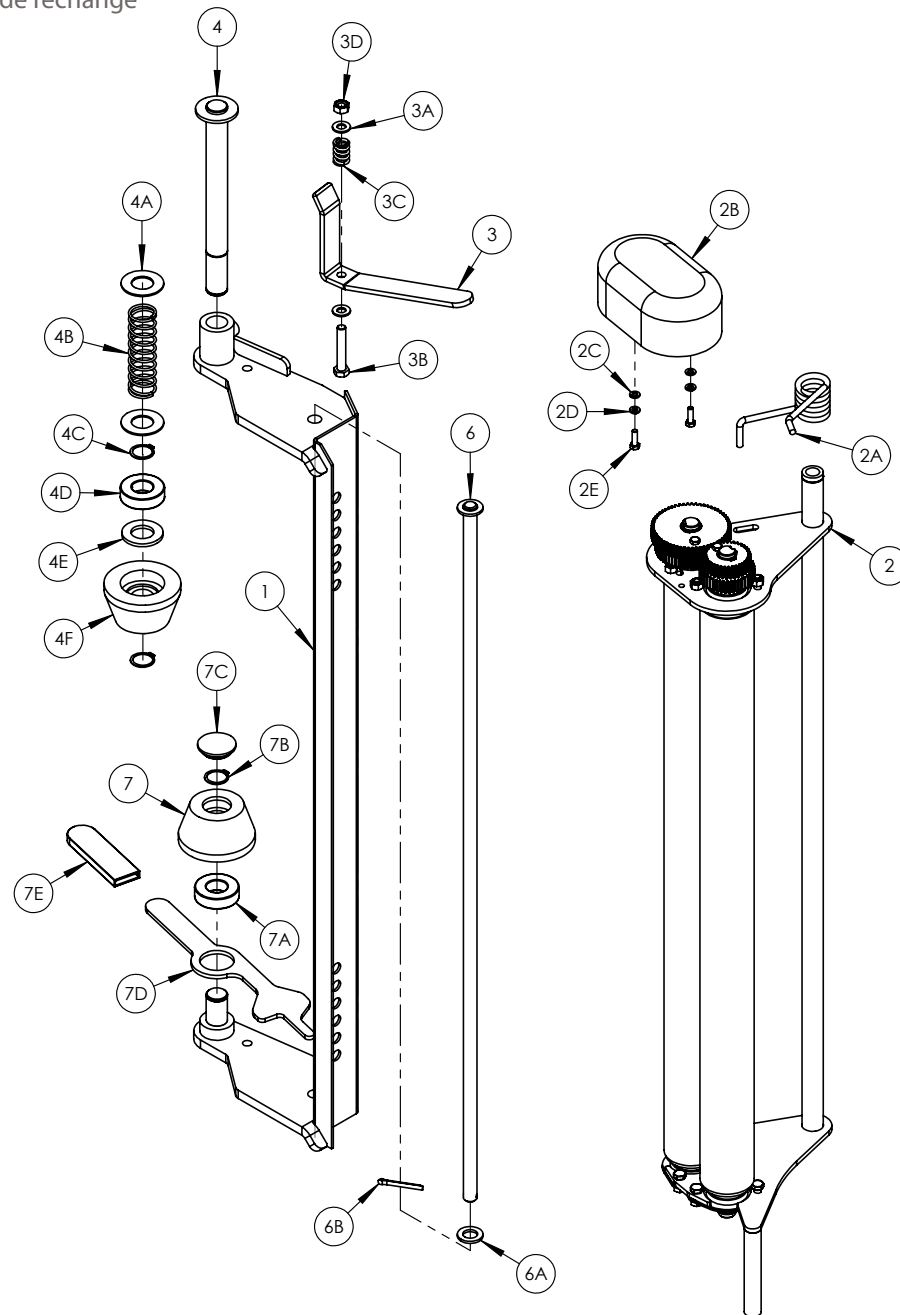

POS. NR. POS. NR. POS. NO.	TEILE NR. PART NR. PIECE NO.	STUCK QUANTITY QUANTITEE	BENENNUNG	DESCRIPTION	DESIGNATION	TECHNISCHE ANGABEN TECHNICAL DATA DONNEES TECHNIQUES
1	2005000	1	Vorstreckerrahmen	Dispenser Frame	Cadre du distributeur	
2	1205100B	1	Einsatzbaugruppe	Insert Assembly	Insert	70/55%
2A	1305034	1	Torsionsfeder	Torsion Spring	Ressort de torsion	
2B	1305125	1	Getriebeverkleidung	Gear Cover	Carter d'engrenage	
2C	Z10-02-06	2	Unterlegscheibe	Flat Washer	Rondelle plate	M6
2D	Z12-02-06	2	Federscheibe	Spring Washer	Rondelle à ressort	M6
2E	Z26-0205	2	Innensechskantschraube	Hex Set	Vis de régl. Hex	M6 x 20mm
3	1305026	1	Arretierung, oben	Top Latch	Loquet supérieur	
3A	Z10-02-10	2	Unterlegscheibe	Flat Washer	Rondelle plate	M10
3B	Z26-067B	1	Sechskantschraube	Hex Bolt	Boulon Hex	M10 x 60mm
3C	1305027	1	Druckfeder	Compression Spring	Ressort à compression	
3D	Z23-10	1	Feststellmutter	Locknut	Contre-écrou	M10
5	1305022	1	Konusstift	Cone Pin	Goupille conique	
5A	Z11-02-25	2	Unterlegscheibe	Flat Washer	Rondelle plate	M25 (LD)
5B	1305021	1	Druckfeder	Compression Spring	Ressort à compression	
5C	Z28-525	2	Seegerring	Cir clip	Circlip	A25
5D	Z06-AWRB	1	Lager	Bearing	Palier	6205-ZZ LDK
5E	Z10-02-25	1	Unterlegscheibe	Flat Washer	Rondelle plate	M25 (HD)
5F	1305019	1	Konus, oben	Top Cone	Cône supérieur	
6	1303530	1	Einsatz, Stift	Insert Pin	Goupille de l'insert	
6A	Z10-02-16	1	Unterlegscheibe	Flat Washer	Rondelle plate	M16
6B	Z03-21-14	1	Splint	Split Pin	Goupille fendue	3/16" x 1 1/2"
7	1305016	1	Konus, unten	Bottom Cone	Cône inférieur	
7A	Z06-AWRB	1	Lager	Bearing	Palier	6205-ZZ LDK
7B	Z28-525	1	Seegerring	Cir clip	Circlip	A25
7C	Z32-15F	1	Rohreinsatz (37 mm)	Tube Insert (37mm)	Insert de tube (37 mm)	Ø37mm
7D	2005005	1	Entriegelungsbügel	Release Bracket	Ergot de dégagement	
7E	Z32-165	1	Plastikgriff	Plastic Grip	Embout plastique	